

Low Voltage Battery System
TommaTech Hightech Power S LV Series

User Manual

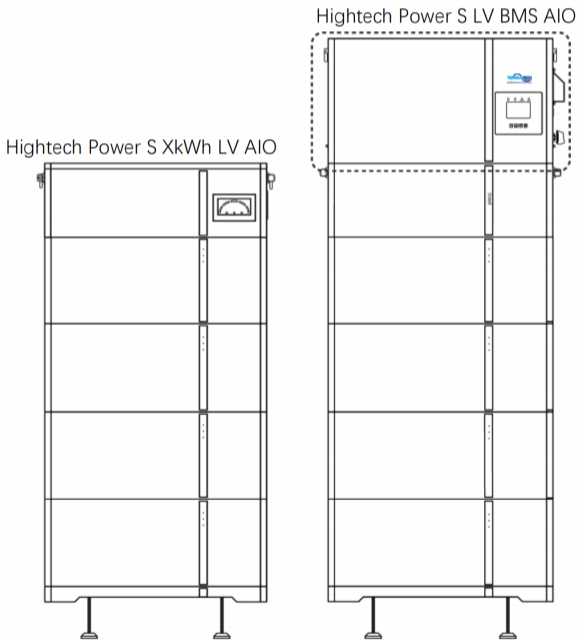

Hightech Power S 5.1kWh LV AIO

How to Use This Manual

Read the manual and other related documents before performing any operation on the battery. Documents must be stored carefully and be always available. Contents may be periodically updated or revised due to product development. The information in this manual is subject to change without notice.

The latest manual can be acquired via www.tommatech.de (service-mail@tommatech.de).

All Rights Reserved

No part of this document can be reproduced in any form or by any means without the formal permission of the manufacturer.

Trademarks and Permissions

Trademarks used in this manual are owned by the manufacturer. All other trademarks or registered trademarks mentioned in this manual are owned by their respective owners.

Software Licenses

- * It is prohibited to use data contained in firmware or software developed by the manufacturer , in part or in full, for commercial purposes by any means.
- * It is prohibited to perform reverse engineering, cracking, or any other operations that compromise the original program design of the software developed by the manufacturer.

Disclaimer

The manufacturer shall not be liable for personal injury, property loss, product damage and subsequent losses under the following circumstances:

- * Damages caused by force majeure, including earthquake, flood, volcanic eruption, mudslide, lightning, fire, war, military conflict, typhoon, hurricane, and so on.
- * Failure to comply with the provisions of this manual.
- * Installation, operation or storage environment fails to meet international, national or regional standards.
- * Incorrect use of this product.
- * Unauthorized/unqualified personnel repair, disassemble or operate the product/rack.
- * Use of unapproved spare parts.
- * Unauthorized modifications or technical changes to the product or software.
- * Incorrect shipment by yourself or the third party commissioned by you.
- * Unsatisfactory materials and tools from you own that do not meet the relevant international, national or regional standards.
- * Damage caused by yourself or the third party's negligence, intent, gross negligence, or improper operation.

CONTENTS

1 Safety Instructions.....	3
1.1 Terms and Symbols.....	3
1.2 Safety Rules.....	4
2 General Technical Requirements.....	6
2.1 Product Description.....	6
2.1.1 Product Features.....	6
2.1.2 Application Scenarios.....	6
2.1.3 SN Code Description.....	7
2.1.4 Product Overview.....	8
2.2 Preparation for Installation.....	8
2.2.1 Required Tools.....	8
2.2.2 Safety Gear.....	9
2.2.3 Unpacking List.....	9
2.3 Installation Instructions.....	10
2.3.1 Installation Torque.....	10
2.3.2 Installation Personnel.....	10
2.3.3 Installation Environment.....	11
2.4 Electrical Connection.....	13
2.4.1 Visual Inspection of the Connection.....	13
3 Specific Technical Requirements for Battery Pack.....	14
3.1 Product Introduction.....	14
3.2 Preparation for Installation.....	15
3.3 Installation Instructions.....	15
4 Specific Technical Requirements for Hightech Power S LV BMS.....	17
4.1 Product Introduction.....	17
4.2 Preparation for Installation.....	18
4.3 Installation Instructions.....	20
4.3.1 Selection of Installation Sites.....	20
4.3.2 Installation Method.....	22
4.4 Electrical Connection.....	26
4.4.1 System Connection Precautions.....	26

4.4.2 Preparation before Wiring.....	27
4.4.3 Wire Connection.....	29
4.4.4 Grounding.....	32
4.5 Turn on/off the System.....	33
5 Specific Technical Requirements for Hightech Power S LV BMS AIO.....	35
5.1 Product Introduction.....	35
5.2 Preparation for Installation.....	36
5.3 Installation Instructions.....	37
5.3.1 Selection of Installation Sites.....	37
5.3.2 Installation Method.....	40
5.4 Electrical Connection.....	42
5.4.1 System Connection Precautions.....	42
5.4.2 Preparation before Wiring.....	43
5.4.3 Wire Connection.....	43
5.4.4 Grounding.....	45
5.5 Turn on/off the System.....	47
6 Monitoring.....	48
7 Inspection, Cleaning and Maintenance.....	50
7.1 General Information.....	50
7.2 Inspection.....	50
7.3 Cleaning.....	51
7.4 Maintenance.....	51
8 Storage.....	52
9 Troubleshooting.....	53
10 Environmental Disposal.....	54
11 Transportation Requirements.....	55
12 Technical Specifications.....	56
13 EU Declaration of Conformity.....	58
Annex I-Manufacturer Self Declaration.....	59









1 Safety Instructions











Warning!

Read and follow carefully all safety warnings and all instructions . Failure to do so may result in electrical shock, fire, serious injury, or death. Save these instructions for future reference.

1.1 Terms and Symbols

Terms /Symbols	Description
 Danger	Indicates a hazard with a high level of risk which, if not avoided, will result in death or serious injury
 Warning	Indicates a hazard with a medium level of risk which, if not avoided, will result in death or serious injury.
 Caution	Indicates a hazard with a low level of risk which, if not avoided, will result in minor or moderate injury.
 Notice	Indicates a potentially hazardous situation which, if not avoided, could results in equipment damage, data loss, performance deterioration, or unanticipated results. NOTICE is used to address practices not related to personal injury.
 Note	Supplements the important information in the main text. NOTE is used to address information not related to personal injury, equipment damage, and environment deterioration.
	Caution , risk of electric shock symbol indicates important safety instructions, which if not correctly followed , could result in electric shock.
	The DC input terminals of the inverter must not be grounded.
	Surface high temperature. Please do not touch the inverter case.
	CE mark of conformity

	Please read the instructions carefully before use.
	Indicate that this product is recyclable
	Do not place near open fire or incinerate. Do not use near heaters or hot temperature source.
	Attention! The risk of explosion.
	Li-ion battery
	Do not tread
	Do not run and chase
	Do not touch with your palm
	Symbol for the marking of electrical and electronics devices according to Directive 2002/96/ EC. Indicates that the device , accessories and the packaging must not be disposed as unsorted municipal waste and must be collected separately at the end of the usage. Please follow Local Ordinances or Regulations for disposal or contact an authorized representative of the manufacturer for information concerning the decommissioning of equipment.

1.2 Safety Rules

- 1) After unpacking, please check product and packing list first, if product is damaged or lack of parts, please contact with the local retailer.
- 2) Before installation, be sure to cut off the grid power and make sure the battery is in the turned-off mode.
- 3) Wiring must be correct. Be careful to negative pole and positive of cable and terminals. Make sure no short circuit with the external device.

- 4) It is prohibited to connect the battery and AC power directly.
- 5) Please ensure the electrical parameters of the battery system are compatible with related equipment.
- 6) Do not allow the terminals to contact exposed wire or metal.
- 7) Keep out of reach of children or animals.
- 8) Do not place batteries near fire, heater or high temperature sources. This will reduce the risk of explosion or possible injury.
- 9) Batteries can explode in the presence of a source of ignition, such as open flame. An exploded battery can propel debris and chemicals. If it occurs, flush with water immediately.
- 10) Do not submerge the battery in water or expose it to moisture when the product is in an incomplete state; the Ingress Protection Rating of this product is **IP65** and this product is waterproof when in a complete state. Do not disassemble or alter the battery in any way.
- 11) If the battery system needs to be moved or repaired, the power must be cut off and the battery is completely shut down.
- 12) It is prohibited to connect the battery with a different type of battery.
- 13) It is prohibited to put the batteries into use with a faulty or incompatible inverter.
- 14) It is prohibited to disassemble the battery.
- 15) In case of fire, only dry fire extinguishers can be used. Liquid fire extinguishers are forbidden.
- 16) Please do not open, repair, or disassemble the battery except qualified personnel. We do not undertake any consequences or related responsibility which result from a cause of violation of safety operation or violating of design, production, and equipment safety standards.
- 17) BATTERY NEEDS TO BE RECHARGED WITHIN 48 HOURS AFTER FULLY DISCHARGED. IT IS RECOMMENDED TO KEEP THE SOC ABOVE 5% DURING USE TO AVOID OVER-DISCHARGE.
- 18) Do not expose cable outside.
- 19) Do not expose battery to flammable or harsh chemicals or vapors.
- 20) Do not paint any part of battery, include any internal or external components.
- 21) Do not connect battery with PV solar wiring directly.
- 22) Any foreign object is prohibited to insert into any part of battery.
- 23) Do not strike, drop, puncture or step on the battery. A damaged battery is subjected to explosion. Properly dispose of damaged battery immediately.
- 24) In case of electrolyte leakage, keep leaked electrolyte away from contact with eye or skin. If that occurs, wash immediately with clean water for at least 10 minutes, then seek immediate medical attention.

2 General Technical Requirements

2.1 Product Description

2.1.1 Product Features

- 1) The lithium iron phosphate battery is one of new energy storage products, which can be used to support reliable power for various types of equipment and systems. The whole module is non-toxic, non-polluting, and environmentally friendly.
- 2) This product has built-in BMS battery management system, which can manage and monitor cells information including voltage, current and temperature. What's more, BMS can balance cells charging and discharging to extend cycle life.
- 3) Cathode material is made from LiFePO₄ with safety performance and long cycle life.
- 4) Flexible configuration. Multiple batteries can be in parallel for expanding capacity and power.
- 5) Adopted self-cooling mode rapidly reduces system noise.
- 6) The module has less self-discharge, no memory effect, excellent performance of shallow charge and discharge.
- 7) Battery module communication address auto networking, easy maintenance, support remotely monitoring and upgrade the firmware.
- 8) High-power density: flat design, stack-mounted, saving installation space.
- 9) Restricted-current charging module can help improve battery life.

2.1.2 Application Scenarios

This energy storage system adopts a design where the same battery pack is compatible with two differentiated LV BMS (Power Distribution Units). Both LV BMS support external photovoltaic power supply and can realize core functions such as household load power supply, daily electricity supply and grid connection. The specific differences in configuration and operation mode are as follows:

- Hightech Power S LV BMS Configuration and Function Implementation

Hightech Power S LV BMS must be used with an external matching inverter.

It completes power conversion and regulation through the inverter, suitable for installation scenarios requiring flexible inverter matching.

- Hightech Power S LV BMS AIO Configuration and Function Implementation

Hightech Power S LV BMS AIO can be integrated with a matching inverter into an integrated design, directly realizing the same

core functions mentioned above. It is suitable for scenarios requiring compact installation and integrated operation and maintenance.

Consult with your system integrator for other possible system architectures depending on your requirements.

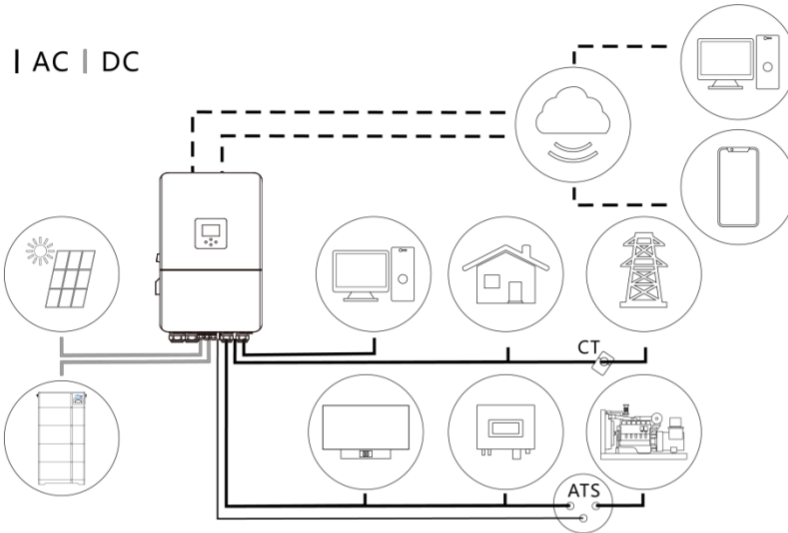

The picture is only a reference picture, please refer to the actual product, the final interpretation right belongs to TOMMATECH.

2.1.3 SN Code Description

Users can distinguish whether the battery pack is equipped with the heating function and check its production-related information via the SN Code.

SN code	No.	Description
<p><u>056</u> <u>XX</u> <u>XXX</u> <u>X</u> <u>X</u> <u>XX</u> <u>XXXX</u></p> <p>1 2 3 4 5 6 7</p>	1	Model/Version Code: 3-digit code(e.g., 056: without heating film)
	2	Production Line Code: 2-digit code, 01–99
	3	Customer Code: 3-digit code(refer to customer code table)
	4	Production Date - Year: 1-digit code(A for 2022, cycling A–Z)
	5	Production Date - Month: 1-digit code(1–9, A/B/C representing October–December)

	6	Production Date - Day: 2-digit code, 01–31
	7	Serial Number: 4-digit code, 0001–9999
<p><u>295</u> <u>XX</u> <u>XXX</u> <u>X</u> <u>X</u> <u>XX</u> <u>XXXX</u></p> <p>1 2 3 4 5 6 7</p>	1	Model/Version Code: 3-digit code(e.g., 295: with heating film)
	2	Production Line Code: 2-digit code, 01–99
	3	Customer Code: 3-digit code(refer to customer code table)
	4	Production Date - Year: 1-digit code(A for 2022, cycling A–Z)
	5	Production Date - Month: 1-digit code(1–9, A/B/C representing October–December)
	6	Production Date - Day: 2-digit code, 01–31
	7	Serial Number: 4-digit code, 0001–9999

2.1.4 Product Overview

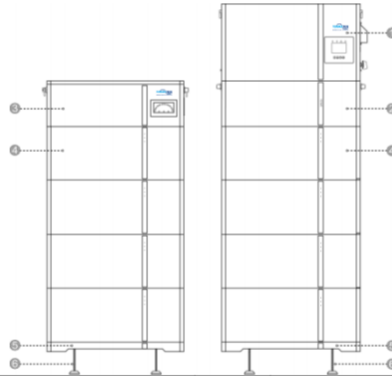







①	Inverter	④	Battery Pack
②	Hightech Power S LV BMS AIO	⑤	Base
③	Hightech Power S LV BMS	⑥	Adjusting Block



2.2 Preparation for Installation

2.2.1 Required Tools

These tools are required to install the battery.

		
Hammer	Drill	Tape measure

		
Hexagon socket wrench	Phillips screwdriver	Hex screwdriver

		
Marker	Precision Level	



Note:

Use properly insulated tools to prevent accident tale electric shock or short circuits. If insulated tools are not available, cover the entire exposed metal surfaces of the available tools, except their tips, with electrical tape.

2.2.2 Safety Gear

It is recommended to wear the following safety gear when dealing with the battery pack.

		
Insulated gloves	Safety shoes	Safety goggles

2.2.3 Unpacking List

Verify the accessory list against the corresponding product. After unpacking, check that packing contents are intact and complete, and free from any damage. If any item listed in the Unpacking List is missing or damaged, contact your vendor.

2.3 Installation Instructions

2.3.1 Installation Torque

Applicable for: Battery pack cabinet assembly / Sheet metal fixing / Bracket connection.

Note: ① Strictly follow the recommended torque, avoid over-tightening/under-tightening ② Unit: N-m (Newton meters)

Bolt Specification	Recommended Torque	Unit
M3	0.7 ~ 0.9	N-m
M4	1.6 ~ 2.2	N-m
M5	3.2 ~ 4.4	N-m
M6	5.3 ~ 7.4	N-m
M8	12 ~ 19	N-m
M10	25 ~ 38	N-m
M12	44 ~ 65	N-m
M14	54 ~ 108	N-m
M16	110 ~ 165	N-m
M18	150 ~ 240	N-m
M20	216 ~ 335	N-m

Supplementary Instructions

- ① The torque value is for reference only for standard bolts during normal assembly; adjust appropriately for special working conditions (high vibration/harsh environment).
- ② Use a calibrated torque wrench for installation to ensure torque accuracy.

2.3.2 Installation Personnel

- Only qualified professionals or trained personnel are allowed to install the equipment.
 - Professionals:personnel who are familiar with the working principles and structure of the equipment, trained or experienced in equipment operations and are clear of the sources and degree of various potential hazards in equipment installation.
 - Trained personnel:personnel who are trained in technology and safety have required experience,are aware of possible hazards on themselves in certain operations and are able to take protective measures to minimize the hazards on themselves and other people.
- Personnel who plan to install the equipment must receive all necessary safety precautions and local

relevant standards.

- Only qualified professionals are allowed to remove safety facilities and inspect the equipment.
- Knowledge of electronic, electrical wiring and mechanical expertise, and be familiar with electrical and mechanical schematics.
- Understanding and complying with this document and other applicable documents.

2.3.3 Installation Environment



Danger!

Do not expose the equipment to flammable or explosive gas or smoke. Do not perform any operation on the equipment in such environments.



Danger!

Do not store any flammable or explosive materials in equipment area. Do not cover or wrap the battery.



Danger!

Do not place the equipment near heat sources or fire sources, such as smoke, candles, heaters, or other heating devices. Overheat may damage the equipment or cause a fire.



Warning!

Install the equipment in an area far away liquids. Do not install it under areas prone to condensation, such as under water pipe and air exhaust vent, or area prone to water leakage, such as air conditioner vents, ventilation vents, or feeder windows of the equipment room. Ensure that no liquid enters the equipment to prevent faults or short circuits.



Warning!

To prevent damage or fire due to high temperature, ensure that the ventilation vents or heat dissipation systems are not obstructed or covered by other objects while the equipment is running.

- The installation and usage environment must meet relevant international, the local laws and regulations. The user is obliged to protect the equipment against fire or other hazards.
- Keep the equipment out of the reach of children and away from daily working or living area, including but not limited to the following areas: studio, bedroom, lounge, living room, music room, kitchen, game room, room theater, sunroom, toilet, bathroom, laundry, and attic.

- Do not install the equipment in places that are enclosed, poorly-ventilated without proper fire fighting facilities, or difficult for firefighters to access.
- Do not install the equipment in an easily accessible position because the temperature of the enclosure and heat sink is high when the equipment is running.
- Do not install the equipment on a moving object, such as ship, train, or car.
- Ensure that the equipment is installed in a clean, dry and well ventilated area with proper temperature, humidity and altitude range. Check for more data in the "Technical Specifications" section.
- Do not install the equipment in an environment with magnetic dust, volatile or corrosive gases, infrared and other radiations, organic solvents, conductive metal, or salty air.
- Do not install the equipment in an area conducive to growth of microorganism such as fungus or mildew.
- Do not install the equipment in an area with strong vibration, noise, or electromagnetic interference.
- Do not install the equipment in an position that may be submerged in water.
- Keep away from the air outlet of inverter to prevent personal injury..
- The floor and wall at the installation location shall be fully waterproof with a flat and level surface.
- Before installing and powering up the system, dust and iron filings must be removed to keep the environment clean. The system cannot be installed in desert areas without a shell to protect against sand.
- This product may be installed indoors and outdoors. To prolong the battery's lifespan, please try to avoid direct sunlight exposure, direct rainwater impact, snow cover, and being close to fire sources, etc.



Caution!

Moving heavy objects. Be careful to prevent injury when moving heavy objects. Select an suitable way to moving heavy objects according to product weight.

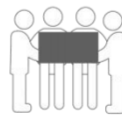

Weight	Method	Recommendation
<18 kg (40 lbs)	Manual handling	1 person
18~32 kg (40~70 lbs)	Manual handling	2 persons
32~55 kg (70~121 lbs)	Manual handling	3 persons
55~68 kg (121~150 lbs)	Manual handling	4 persons

> 68 kg (150lbs)	Moving device	Forklift
------------------	---------------	----------

2.4 Electrical Connection

2.4.1 Visual Inspection of the Connection

After connecting the battery, verify the following items:

- Correct polarity of positive and negative cable connections
- Secure and reliable connection of positive and negative terminals
- All bolts are tightened to the specified torque values (refer to the installation torque table)
- Proper cable fastening and intact cable appearance
- Correct and secure installation of the protective cover

3 Specific Technical Requirements for Battery Pack

3.1 Product Introduction

Battery Pack:

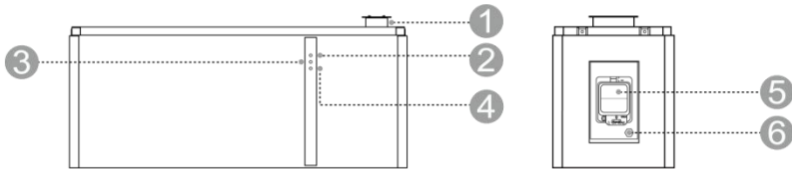

Front view

①	Battery Module Dock Terminal	④	ERROR LED
②	RUN LED	⑤	Circuit Breaker
③	ALARM LED	⑥	Air Vent Valve

RUN LED

Green, keep flashing when the power switch is on.

ALARM LED

Yellow, flashes when battery has alarm.

ERROR LED

Red, long bright if battery is protected.

Circuit Breaker

Built-in overcurrent protection device. It automatically cuts off the circuit when the current abnormally exceeds the safe value, protecting the battery and equipment. A protective cover is fitted externally over the circuit breaker to shield it from external impacts and contamination.

Air Vent Valve

Balances internal and external pressure of the device while preventing the ingress of contaminants such as water, dust, and oil.

Base:

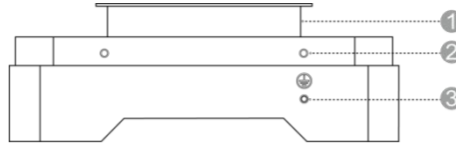

Right view



①	Module Dock Terminal	③	Screw Hole
②	Protective Grounding		

Protective Grounding

Protective grounding for the battery system connecting to the PE.

3.2 Preparation for Installation

After unpacking, check that packing contents are intact and complete, and free from any damage. If any item listed in the Unpacking List is missing or damaged, contact your vendor.

		
Battery Pack*1	User Manual*1	Fixed Support*2 (Thickness:2.5mm)

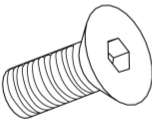
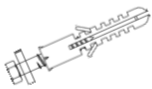
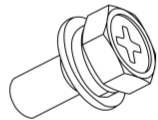
		
Screw*4 (M4*8) (For Fixing Battery Pack)	Expansion Bolt*2 (M6*50)	Bolt*2 (M4*12)

3.3 Installation Instructions



Caution!

- The battery pack is heavy. Be sure to use appropriate equipment (e.g., forklift) for handling and hanging, and ensure multi-person collaborative operation to prevent tipping or falling.

- All screws and expansion bolts must be tightened to ensure firm connection.
- When drilling holes, pay attention to prevent dust from entering the battery, which may affect the battery performance and function. Installer shall avoid the wires and pipes behind the wall when they drill the hole on the wall.
- After drilling, never forget to clean up the floor.



Note!

- The upper and lower enclosures are electrically connected via quick connectors. The upper quick connector may move left and right within the quick connector protection groove due to component manufacturing tolerances. This condition does not affect the normal use of the product.
- To avoid damage to the quick connector, ensure the upper and lower enclosures are properly aligned before stacking. Do not place them at an angle from one side and force them into place. Forced oblique insertion can easily cause the guide pillar to break, resulting in loss of guiding function and affecting product performance.

Lower and upper quick-connectors

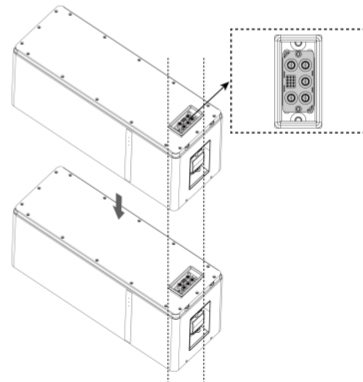
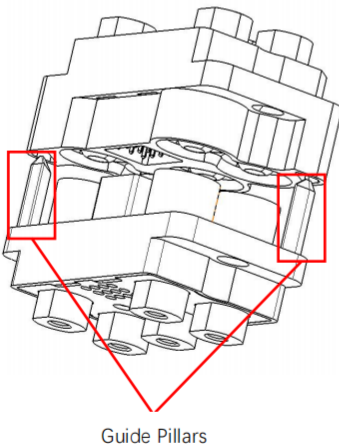

For the complete subsequent installation steps, refer to the “Installation Instructions” section in Hightech Power S LV BMS or Hightech Power S LV BMS AIO.

4 Specific Technical Requirements for Hightech Power S LV BMS

4.1 Product Introduction

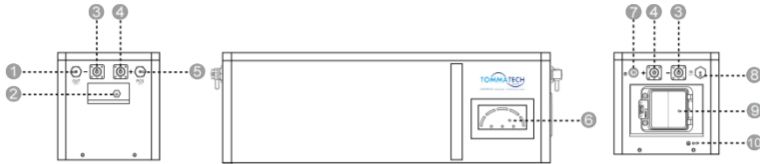

Left view	Front view	Right view
① Parallel Communication Port OUT	⑥ Status Indicator	
② Air Vent Valve	⑦ BMS Switch	
③ Negative Battery Output Port	⑧ Parallel Communication Port IN	
④ Positive Battery Output Port	⑨ Circuit Breaker	
⑤ Inverter CAN/RS485 Port PCS	⑩ Protective Grounding	

Parallel Communication Port OUT

Sends battery pack status and control signals to other parallel-connected devices.

Air Vent Valve

Balances internal and external pressure of the device while preventing the ingress of contaminants such as water, dust, and oil.

Negative Battery Output Port

Provides the negative terminal connection for battery power output.

Positive Battery Output Port

Provides the positive terminal connection for battery power output.

PCS port

Inverter communication terminal: (RJ45 port) follow the CAN protocol (baud rate: 500K), used to output battery information to the inverter.

BMS Switch

Manually activates or deactivates the Battery Management System (BMS) control circuit.

Parallel Communication Port IN

Receives status and control signals from other parallel-connected devices.

Circuit Breaker

Built-in overcurrent protection device. It automatically cuts off the circuit when the current abnormally exceeds the safe value, protecting the battery and equipment. A protective cover is fitted externally over the circuit breaker to shield it from external impacts and contamination.

Protective Grounding

Safety grounding terminal, ensuring reliable grounding of the metal enclosure to prevent electric shock risks.

Status Indicator

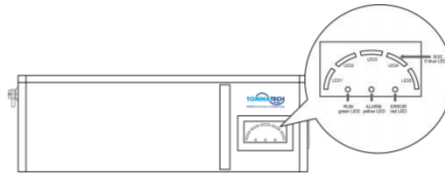

RUN LED: green, keep flashing when power switch is on.

ALARM LED: yellow, flashes when battery has alarm.

ERROR LED: red, long bright if battery is protected.





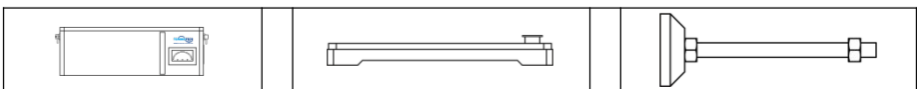

SOC LED: 5 blue LEDs, battery capacity indicator, each light represents 20% capacity.

Condition	RUN	ALARM	Error	LED1	LED2	LED3	LED4	LED5
Power off	off							
Charge	● Blink	● Blink if Alarm Exists	off	● Show SOC & highest LED blink				
Discharge or Idle		off	off	● Show SOC & long bright				
Alarm		● Blink	off	● Other LEDs are same as above				
System error/Protect		off	● long bright					
Upgrade	Blink Fast							
Critical Error	Blink Slowly							

4.2 Preparation for Installation

After unpacking, check that packing contents are intact and complete, and free from any damage. If any item listed in the Unpacking List is missing or damaged, contact your vendor.

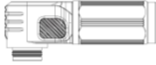
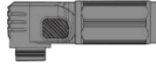

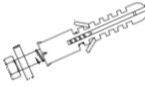
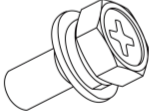
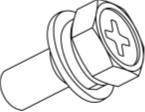
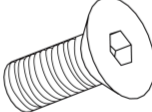
LV BMS*1	Base*1	Adjusting Block *4
		
2000mm RJ45 communication cable*1	Positive cable*1	Negative cable*1
		
600mm ground cable*1	Positive terminal *2	Negative terminal *2
		
Fixed support*2 (thickness:2.5mm)	User manual*1	Expansion bolt*2 (M6*50)
		
Bolt*2 (M4*12) (For securing fixed support)	Bolt*1 (M4*12) (For grounding)	Screw*4 (M4*8) (For fixing PDU)

4.3 Installation Instructions

4.3.1 Selection of Installation Sites

If the installation site is limited, you can refer to the following layout for installation.

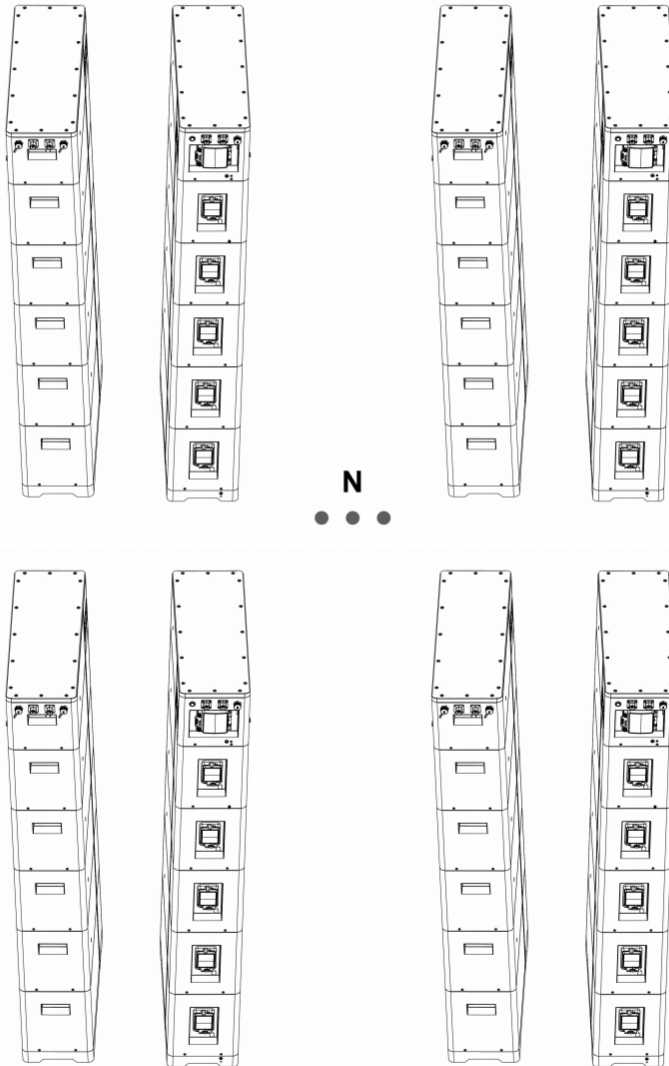



Caution!

Batteries should be installed in a clean flat place with no direct sunlight, away from water and fire sources, and at a suitable temperature.

The installation location is recommended to meet the size requirements of the figure below:

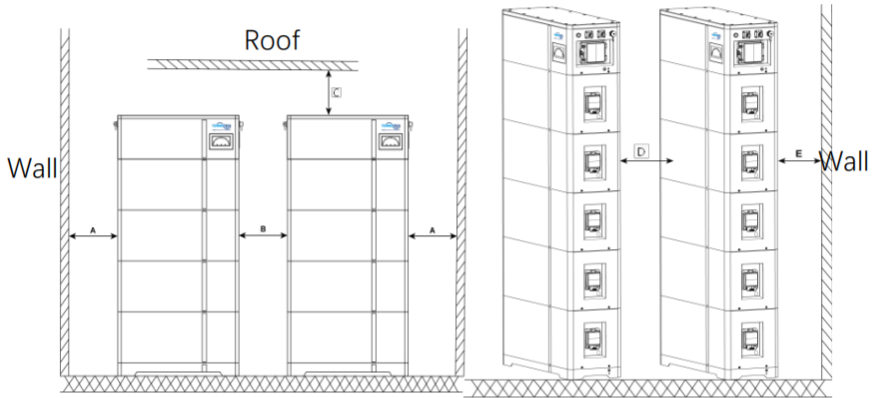

Item	Distance (mm)
A	≥ 300
B	≥ 300
C	≥ 300
D	≥ 20
E	10-35

There are two installation methods for you to make a decision.

4.3.2 Installation Method

Method 1

Step 1. Take out the base and then put it onto the designated foundation. Stack batteries onto the base in turn and then place the LV BMS over the battery.

The quantity of stacked batteries that are regarded as one cluster, is no more than 6.



Step 2. Secure with M4*8 screws using a screwdriver. Recommended torque: 1.6 ~ 2.2 N·m

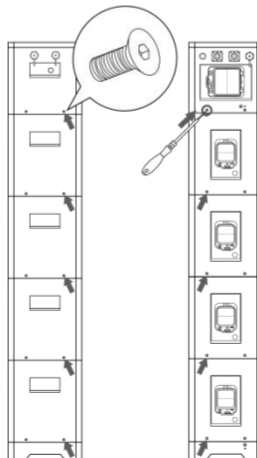

Step 3. Use M4*12 bolts (Mounting Screw) and M6*50 expansion bolts to secure fixed supports to the left and right side of batteries, LV BMS and base. Recommended torque for M4*12 bolts: 1.6 ~ 2.2 N·m; Recommended torque for M6*50 bolts: 5.3 ~ 7.4 N·m

M4*12 Bolts (Mounting Screw):

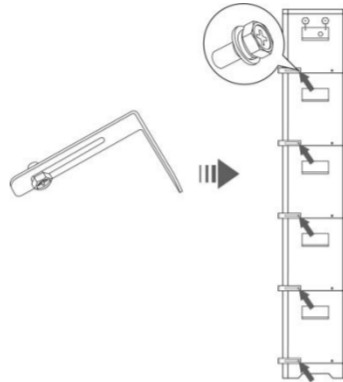

M6*50 Expansion Bolts:

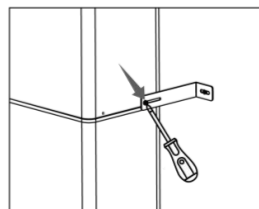
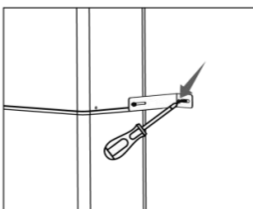
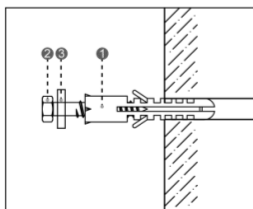
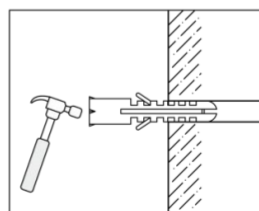
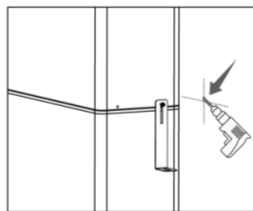
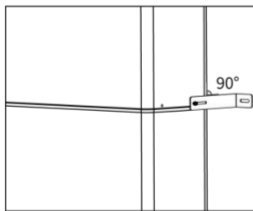
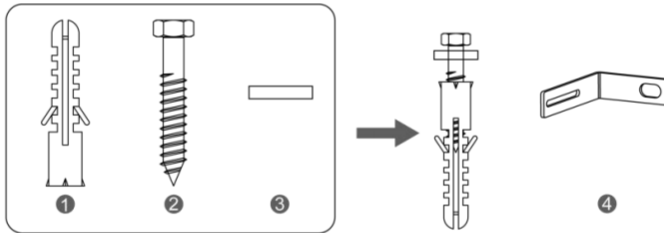

①: plastic expansion tube; ② expansion screw; ③ washer; ④ fixed support

- (1) Pre-install **Fixed Support**: Screw the **fixed support (④)** lightly into the mounting hole on the device body (do not fully tighten to leave adjustment margin). Then, position the **fixed support** flat against the wall at a 90° angle.
- (2) Drill Hole in Wall: Align the drill bit with the hole on the **fixed support**, and use an electric drill to drill a hole in the wall that match the size of the **expansion tube**. (Hole specifications: hole spacing 10 mm, hole depth 60 mm.)
- (3) Insert Expansion Tube: Tap the **plastic expansion tube (①)** into the drilled wall hole with a hammer.
- (4) Assemble Expansion Bolt: Slide the **washer (③)** onto the **expansion screw (②)**. Pass the assembled screw through the **fixed support (④)** and align them with the **expansion tube** embedded in the wall.
- (5) Tighten Expansion Bolt: Use a screwdriver to tighten the screw until the **expansion tube** expands inside the wall, securing **the fixed support** firmly to the wall surface.
- (6) Tighten **Mounting Screw**: Adjust the **fixed support** to the desired position, then fully tighten the **mounting screw** on the device body.

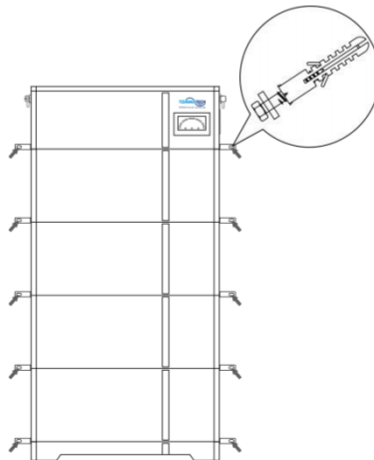

Method 2

Step 1. By rotating clockwise, the adjusting block is fixed on the base, and the length can be adjusted to

40mm.

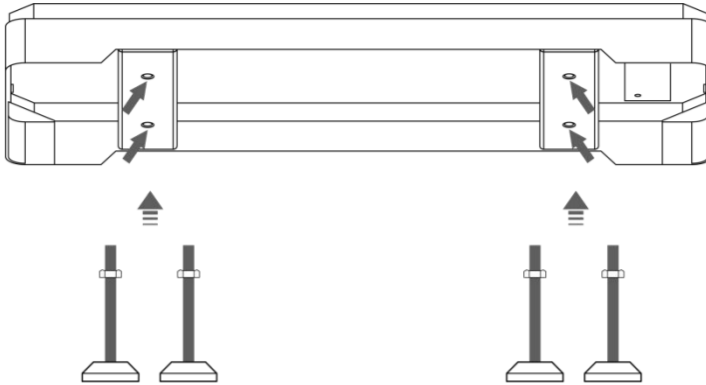

Step 2. Rotate the adjusting blocks to make an initial height adjustment, then use a precision level to check and fine-tune the horizontal level of the assembly. Lock the adjusting blocks in place once the surface is confirmed to be level.



Step 3. Stack battery packs and the LV BMS, and then secure with screws as mentioned in the "Step 2" of **method 1**. The quantity of stacked batteries that are regarded as one cluster, is no more than 6.



Step 4. Use M4*12 bolts (Mounting Screw) and M6*50 expansion bolts to secure fixed supports to the left and right side of batteries, LV BMS and base. For detailed operating steps, refer to the "Step 3" in **Method 1**.

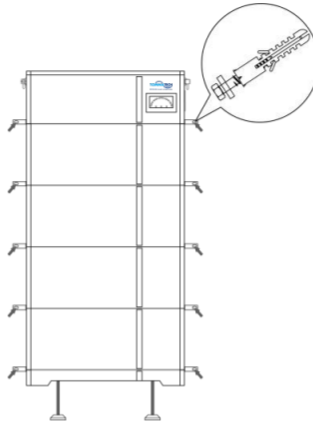

4.4 Electrical Connection

4.4.1 System Connection Precautions



Note

- This battery must be used in conjunction with compatible hybrid inverter models. It needs to establish communication with the inverter to activate the lithium battery mode, ensuring optimal battery performance.



CAUTION

When connecting to inverters or being in parallel mode, please use cables provided in the unpacking list. If other cables must be used in special cases, ensure they meet relevant standards.

Table 1-Connection between Battery System and Inverter:

Inverter Power (kW)	Cable size (AWG)	Cable section (mm ²)
5/6/8/10/12	1/0	50

Table 2-Connection between combiner box and Inverter

Inverter Power (kW)	Cable size (AWG)	Cable section (mm ²)
14 /15/16	2/0	70
18/ 20	3/0	85

Note:

A single battery cluster supports a maximum inverter capacity of 12 kW.

- If an inverter with a power rating >12 kW is connected to only one battery cluster, the connecting cable can be specified as 1/0 AWG (50 mm²).

- If an inverter with a power rating >12 kW, it is recommended to use the **Multiple Battery Systems** connection mode.

4.4.2 Preparation before Wiring



Note

Please perform operations in accordance with actual conditions.

Part 1: Package contents

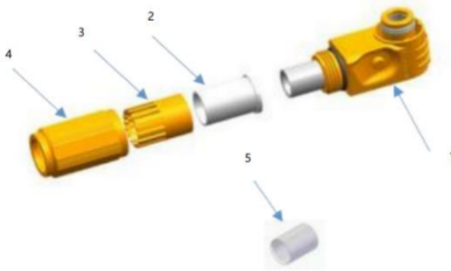

- 1: Socket Package
- 2: Grommet
- 3: Gripping Jaw
- 4: Nut
- 5: Barrel sealing(Only for cable size 35mm²)

Part 2: Plug Assembly Instruction

Step1: Strip off the jacket of the cable.



Step2: Put the nut,the Grommet and the gripping jaw on the cable as shown.



Step3: Insert the conductor into the lug.

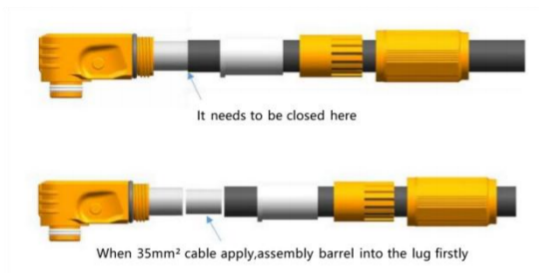

Step4: Crimping the lug as shown.

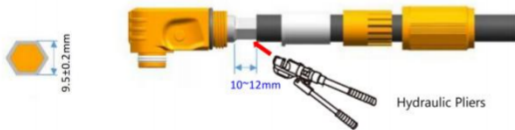

Note: The recommended crimp sizes are only for reference. The customer should adjust them according to cable specification and crimp tool and test results including temperature rise and metallographic analysis and pullout force.

Step5: Push the seal,the jaw and the nut into the socket, then screw it.

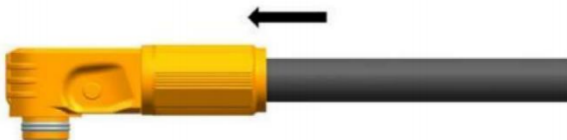

Step6: Schematic diagram of matching plug and socket. (Warning: Do not disconnect under load)



Note

Both ends of the PCS communication cable are equipped with protective sleeves. When connecting the entire battery system to the inverter, loosen the protective sleeve on one side before inserting this end into the BMS port of the inverter, as shown in the figure.

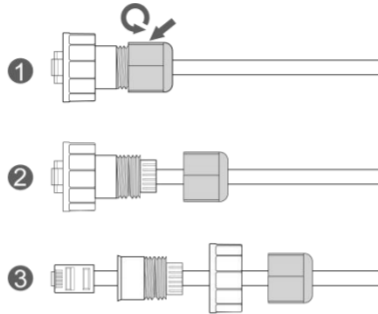

4.4.3 Wire Connection

How to connection?

- Take the positive cable supplied with the equipment, and connect the positive terminal of the Battery Power Distribution Unit (LV BMS) to the corresponding positive terminal of the inverter.
- Take the negative cable supplied with the equipment, and connect the negative terminal of the Battery Power Distribution Unit (LV BMS) to the corresponding negative terminal of the inverter.
- Take the communication cable supplied with the equipment, and connect the communication port of the Battery Power Distribution Unit (LV BMS) to the corresponding communication port of the inverter.

Connection Diagram

For the wiring positions of all components and cable connection methods, refer to the following figure.

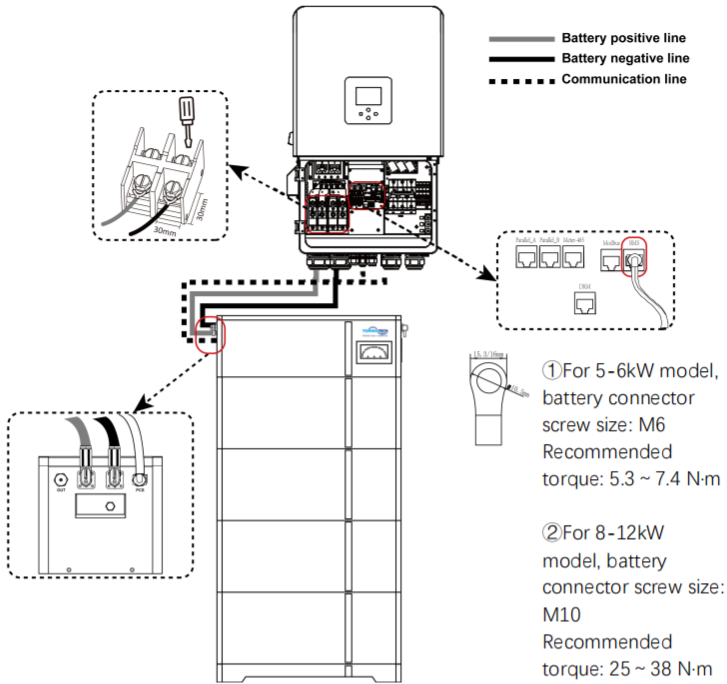

There are **3 different wiring modes** for you to meet your demands.

Schematic diagram of connection of single battery system:

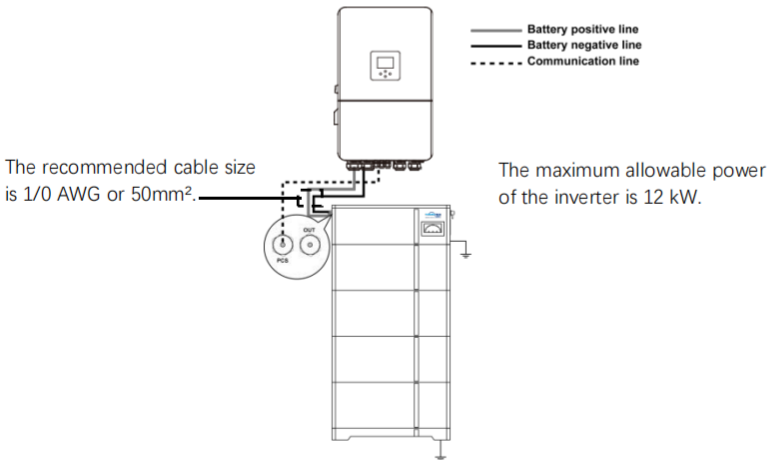

Schematic diagram of connection of multiple battery systems:

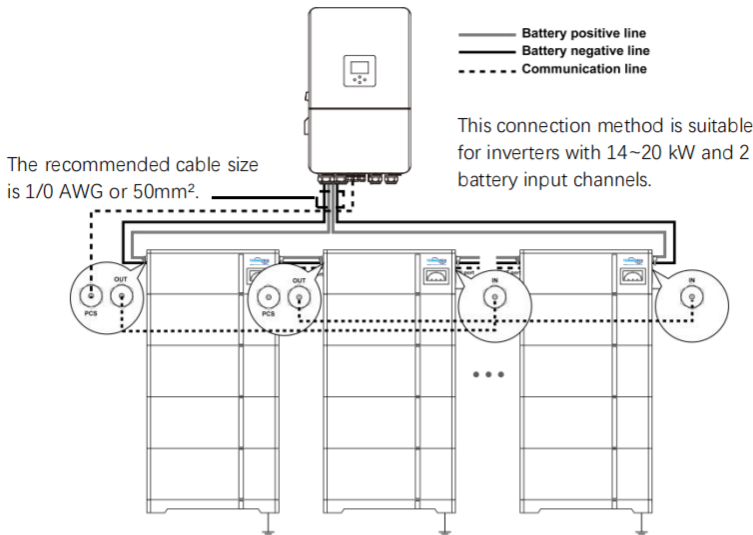

Schematic diagram of connection of multiple inverters and battery systems:

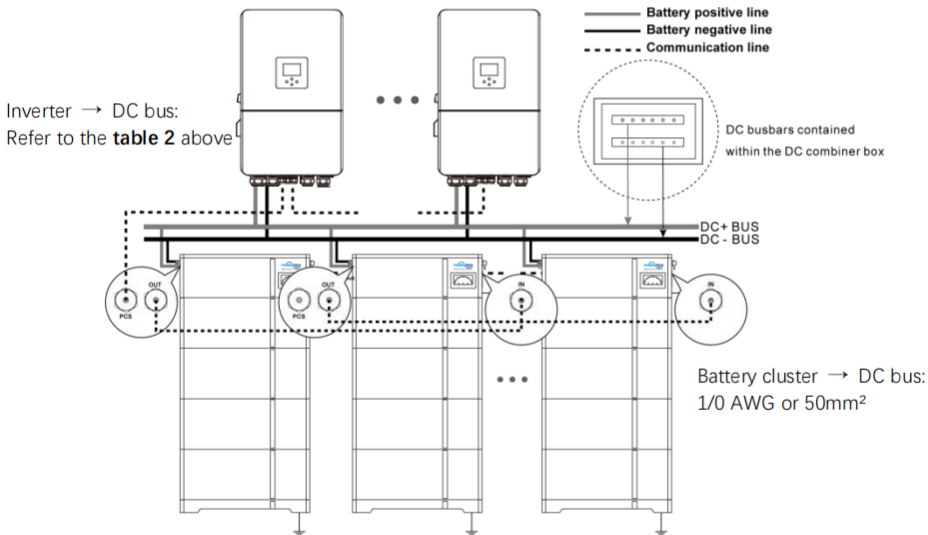

Note

The DC bus and combiner box shall be provided by the customer. The wire size shall be determined by the inverter power rating, and accessories shall be selected in accordance with the inverter's instruction manual.

4.4.4 Grounding

The grounding of the system consists of two parts: battery pack grounding and inverter grounding.

Battery Pack Grounding

- **Battery Pack Grounding Path (Two Options Available)**
 - Ground via the LV BMS.
 - Ground via the base.
- **Battery Pack Grounding Operation Steps**
 - Locate the dedicated protective grounding point marked  on the equipment.
 - Use a screwdriver to securely fasten the ground cable (yellow-green wire) and the M4*12 bolt to this dedicated protective grounding point. Recommended torque: 1.6 ~ 2.2 N·m

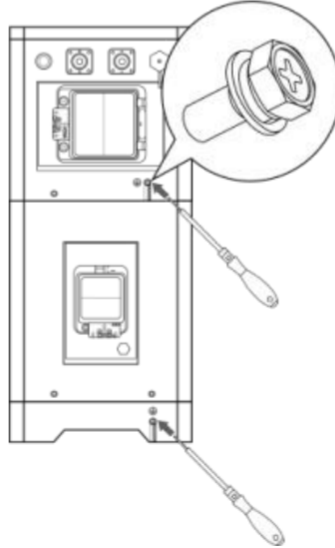

- Connect the other end of the ground cable to the common PE terminal to complete the entire

grounding circuit.

Inverter Grounding

- Grounding Operation Steps
 - Reliably connect the inverter protective grounding to the common PE terminal, using the grounding cable supplied with the inverter. (For detailed steps, please refer to the inverter's manual.)

The grounding diagram of the entire system is shown below.

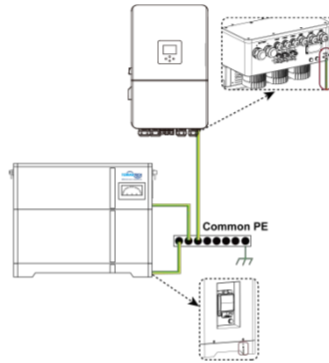

4.5 Turn on/off the System

Start the Battery System

- ① Turn on the circuit breaker on each battery.
- ② Turn on the circuit breaker on the LV BMS.
- ③ Turn on the BMS switch on the LV BMS.
- ④ Turn on the inverter switch.

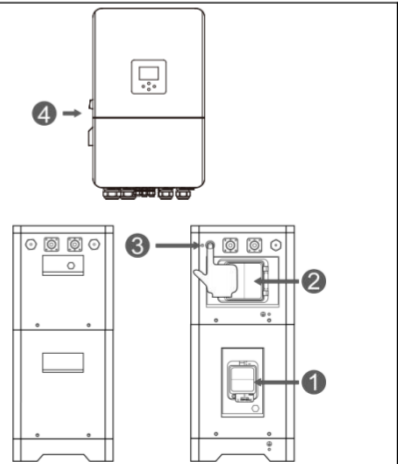

Stop the Battery System

- ① Turn off the inverter switch.
- ② Turn off the BMS switch on the LV BMS.
- ③ Turn off the circuit breaker on the LV BMS.
- ④ Turn off every circuit breaker on each battery.

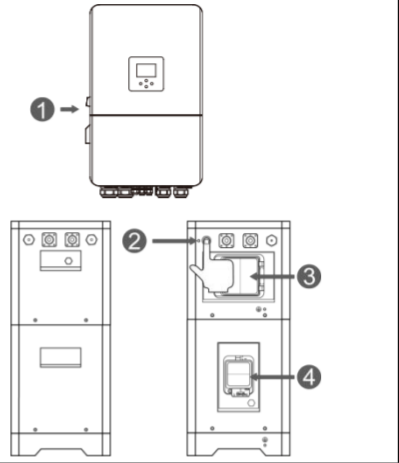

5 Specific Technical Requirements for Hightech Power S LV BMS AIO

5.1 Product Introduction

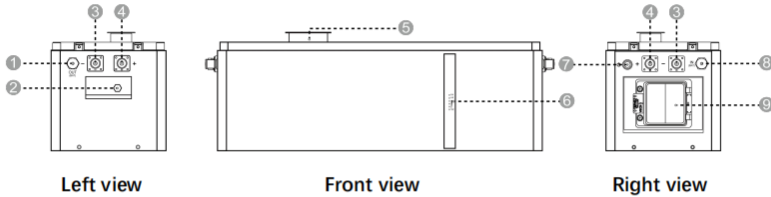

①	Parallel Communication Port OUT	⑥	Status Indicator
②	Air Vent Valve (LV BMS)	⑦	BMS Switch
③	Negative Battery Output Port	⑧	Parallel Communication Port IN
④	Positive Battery Output Port	⑨	Circuit Breaker
⑤	PDU Module Dock Terminal		

Parallel Communication Port OUT

Sends battery pack status and control signals to other parallel-connected devices.

Air Vent Valve

Balances internal and external pressure of the device while preventing the ingress of contaminants such as water, dust, and oil.

PDU Module Dock Terminal

Enables quick, secure connection and power transfer between LV BMS modules and inverter.

Negative Battery Output Port

Provides the negative terminal connection for battery power output.

Positive Battery Output Port

Provides the positive terminal connection for battery power output.

BMS Switch

Manually activates or deactivates the Battery Management System (BMS) control circuit.

Parallel Communication Port IN

Receives status and control signals from other parallel-connected devices.

Circuit Breaker

Built-in overcurrent protection device. It automatically cuts off the circuit when the current abnormally exceeds the safe value, protecting the battery and equipment. A protective cover is fitted externally over the circuit breaker to shield it from external impacts and contamination.

Status Indicator

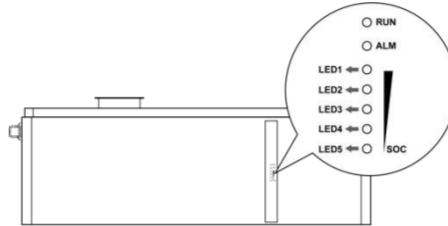

Front view

RUN LED: green, keep flashing when power switch is on.

ALARM LED: yellow, flashes when battery has alarm.



SOC LED: 5 blue LEDs, battery capacity indicator, each light represents 20% capacity.

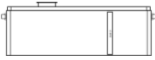
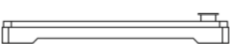
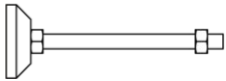

Condition	RUN	ALARM	Error	LED1	LED2	LED3	LED4	LED5
Power off	off							
Charge	● Blink	● Blink if Alarm Exists	off	Show SOC & highest LED blink				
Discharge or Idle		off	off	Show SOC & long bright				
Alarm		● Blink	off	Other LEDs are same as above				
System error/Protect		off	● long bright					
Upgrade	Blink Fast							
Critical Error	Blink Slowly							

5.2 Preparation for Installation

After unpacking, check that packing contents are intact and complete, and free from any damage. If any item listed in the Unpacking List is missing or damaged, contact your vendor.

		
LV BMS*1	Base*1	Adjusting Block *4

		
600mm RJ45 Connector Cable*1	600mm Positive Parallel Power Cable*1	600mm Negative Parallel Power Cable*1

		
600mm Ground Cable*1	User Manual*1	Fixed Support*2 (Thickness:2.5mm)

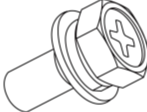
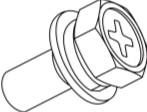
		
Expansion Bolt*2 (M6*50)	Bolt*1 (M4×12) (For Grounding)	Bolt*2 (M4×12) (For Securing Fixed Support)

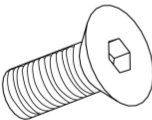
Screw*4 (M4×8) (For Fixing PDU)

5.3 Installation Instructions

5.3.1 Selection of Installation Sites

If the installation site is limited, you can refer to the following layout for installation.

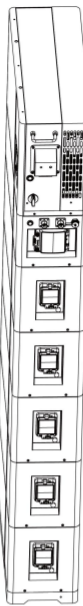

N

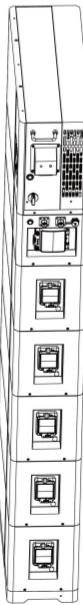



Caution!

Batteries should be installed in a clean flat place with no direct sunlight, away from water and fire sources, and at a suitable temperature.

The installation location is recommended to meet the size requirements of the figure below:

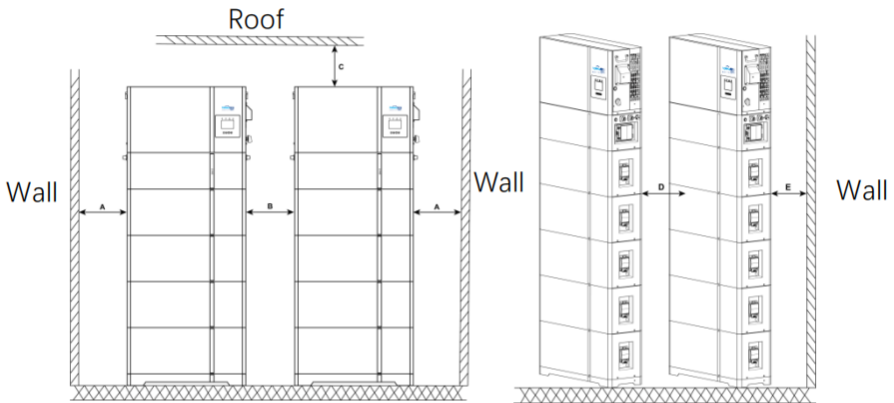

Item	Distance (mm)
A	≥ 300
B	≥ 300
C	≥ 300
D	≥ 20
E	10-35

There are two installation methods for you to make a decision.

5.3.2 Installation Method

Method 1

Step 1. Take out the base and then put it onto the designated foundation. Stack batteries onto the base in turn and then place the LV BMS over the battery.

The quantity of stacked batteries that are regarded as one cluster, is no more than 6.



Step 2. Secure with screws (M4*8) using a screwdriver. Recommended torque: 1.6 ~ 2.2 N·m

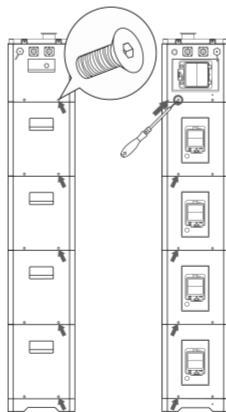

Step 3. Use M4*12 bolts (mounting screw) and M6*50 expansion bolts to secure fixed supports to the

left and right side of batteries, LV BMS and base. Recommended torque for M4*12 bolts: 1.6 ~ 2.2 N·m; Recommended torque for M6*50 bolts: 5.3 ~ 7.4 N·m

The installation steps for M4*12 bolts (Mounting Screw) and M6*50 expansion bolts and the positions where the bolts need to be fixed are the same as those for Hightech Power S LV BMS.

Method 2

Step 1. By rotating clockwise, the adjusting block is fixed on the base, and the length can be adjusted to 40mm.

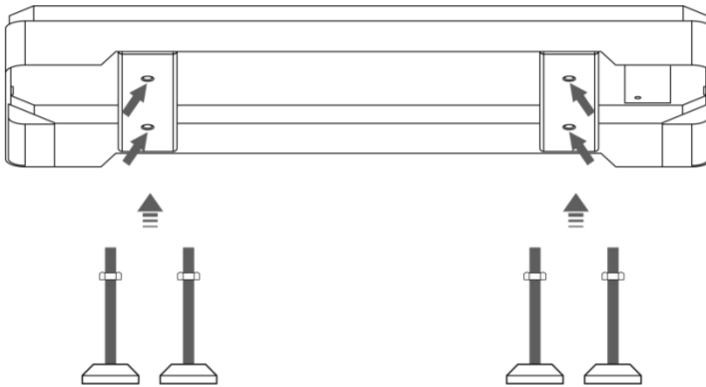

Step 2. Rotate the adjusting blocks to make an initial height adjustment, then use a precision level to check and fine-tune the horizontal level of the assembly. Lock the adjusting blocks in place once the surface is confirmed to be level.



Step 3. Stack battery packs and the LV BMS, and then secure with screws as mentioned in the "Step 2" of **method 1**. The quantity of stacked batteries that are regarded as one cluster, is no more than 6.



Step 4. Use M4+12 bolts (mounting Screw) and expansion bolts to secure fixed supports to the left and right side of batteries, LV BMS and base. For detailed operating steps, refer to the "Step 3 in Method 1.

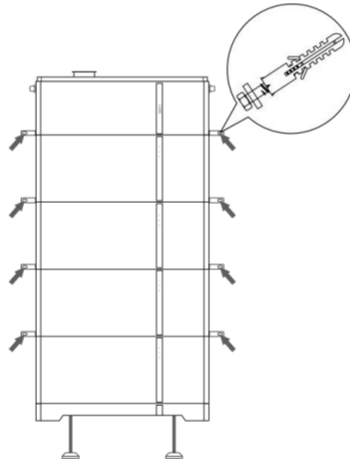

5.4 Electrical Connection

5.4.1 System Connection Precautions



Note:

- This battery must be used in conjunction with compatible hybrid inverter models. (Inverter

recommended: Hightech Power S LV BMS AIO, Hightech Power S 5.1kWh LV AIO It needs to establish communication with the inverter to activate the lithium battery mode, ensuring optimal battery performance.



CAUTION

It should be noted that the maximum power of single battery system is 12kW.

If the maximum power exceeds 12kW, the connection mode must be used **Multiple Battery Systems!**

When connecting to inverters or being in parallel mode, please use cables provided in the unpacking list. If other cables must be used in special cases, ensure they meet relevant standards.

5.4.2 Preparation before Wiring



Note

Both ends of the PCS communication cable are equipped with protective sleeves. When connecting the entire battery system to the inverter, loosen the protective sleeve on one side before inserting this end into the BMS port of the inverter, as shown in the figure.

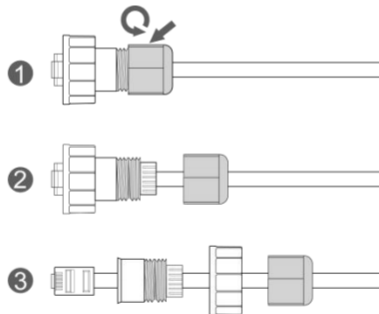

5.4.3 Wire Connection

How to connection?

- Take the positive cable supplied with the equipment, and connect the positive terminal of the Battery Power Distribution Unit (LV BMS) to the corresponding positive terminal of the inverter.
- Take the negative cable supplied with the equipment, and connect the negative terminal of the Battery Power Distribution Unit (LV BMS) to the corresponding negative terminal of the inverter.
- Take the communication cable supplied with the equipment, and connect the communication port of

the Battery Power Distribution Unit (LV BMS) to the corresponding communication port of the inverter

Wiring as shown in the figure below:

Parallel mode 1: Hightech Power S LV BMS AIO(Master)+Hightech Power S LV BMS AIO(Slave)

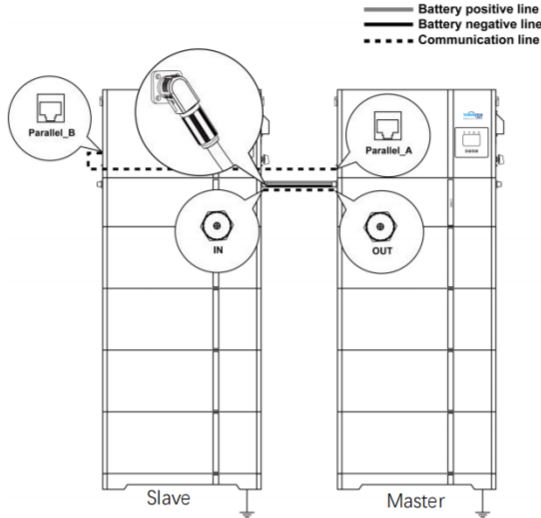

Parallel mode 2: Hightech Power S LV BMS AIO(Master)+Hightech Power S LV BMS(Slave)

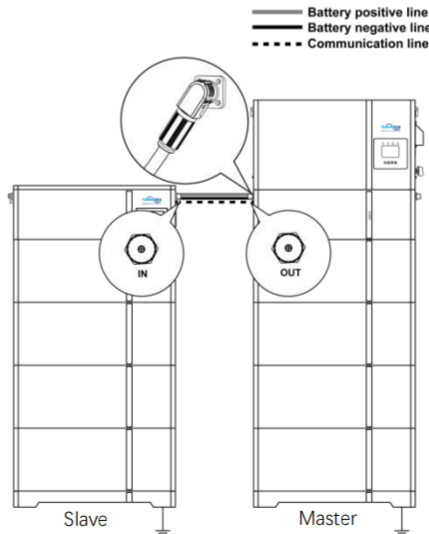

Parallel mode 3: Hightech Power S LV BMS AIO(Master)+external inverter+Hightech Power S LV BMS(Slave)

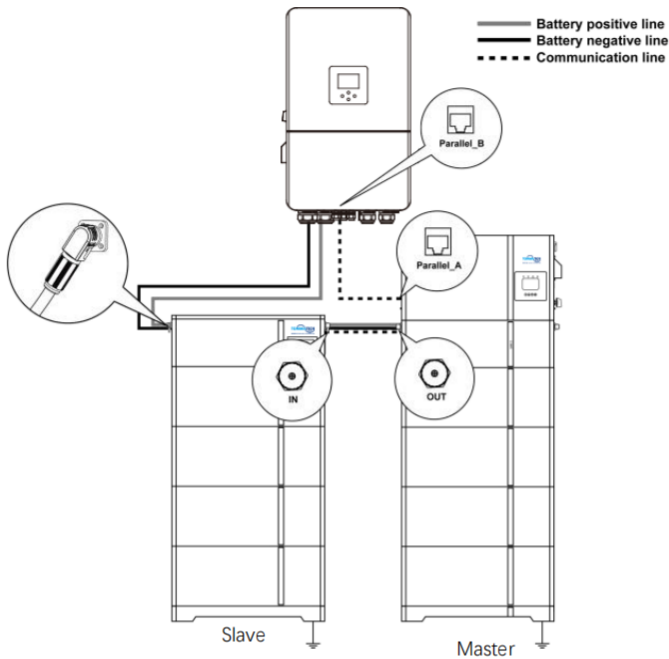

Note

Refer to the product manual of the corresponding inverter for the connection method of the inverter's communication port and power cable.

5.4.4 Grounding

The grounding of the system consists of two parts: battery pack grounding and inverter grounding.

Battery Pack Grounding

- **Battery Pack Grounding Path (Two Options Available)**

- Ground via the LV BMS.
- Ground via the base.

● **Battery Pack Grounding Operation Steps**

- Locate the dedicated protective grounding point marked ⊕ on the equipment.
- Use a screwdriver to securely fasten the ground cable (yellow-green wire) and the M4*12 bolt to this dedicated protective grounding point. Recommended torque: 1.5 N·m

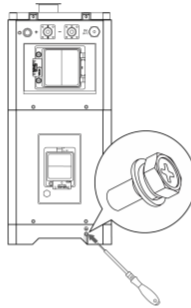

- Connect the other end of the ground cable to the common PE terminal to complete the entire grounding circuit.

Inverter Grounding

● **Grounding Operation Steps**

- Reliably connect the inverter protective grounding to the common PE terminal, using the grounding cable supplied with the inverter. (For detailed steps, please refer to the inverter's manual.)

The grounding diagram of the entire system is shown below.

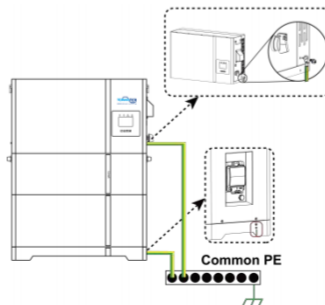

5.5 Turn on/off the System

Start the Battery System

- ① Turn on the circuit breaker on each battery.
- ② Turn on the circuit breaker on the LV BMS.
- ③ Turn on the BMS switch on the LV BMS.
- ④ Turn on the inverter switch.

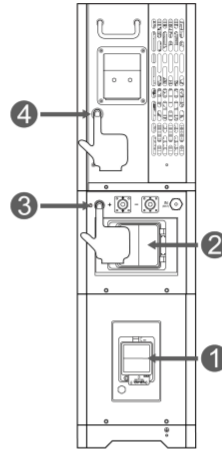

Stop the Battery System

- ① Turn off the inverter switch.
- ② Turn off the BMS switch on the LV BMS.
- ③ Turn off the circuit breaker on the LV BMS.
- ④ Turn off every circuit breaker on each battery.

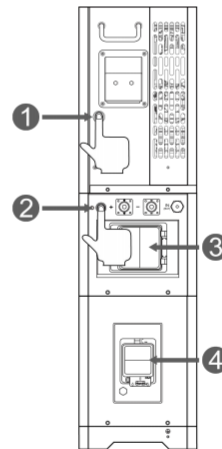

6 Monitoring

Mode 1: TO Monitor parallel units

The first method is to use the upper computer to connect to the communication port of any battery pack and view the status of all packs.

The second method is to connect the PCS communication port of the first battery pack with a network cable, and the other end is connected to the 485 communication port of the inverter. Then, connect the positive pole to the positive pole and the negative pole to the negative pole. Switch the inverter to lithium mode and check the condition of several packs through the inverter display screen.

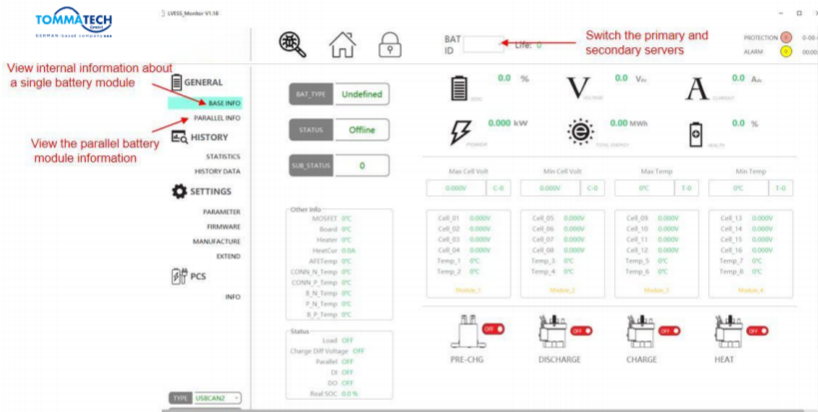

Mode 2: TO Monitor single unit

The first method is to use the upper computer to connect to the communication port of any battery pack and view the status of all packs.

The second method is to connect the PCS communication port of the first battery pack with a network cable, and the other end is connected to the 485 communication port of the inverter. Then, connect the positive pole to the positive pole and the negative pole to the negative pole. Switch the inverter to lithium mode and check the condition of several packs through the inverter display screen.

The screenshot displays the TOMMATECH battery management software interface. On the left, a navigation menu includes options like GENERAL, BASIC INFO, PARALLEL INFO, HISTORY, STATISTICS, HISTORY DATA, SETTINGS, PARAMETER, FIRMWARE, MANUFACTURE, EXTEND, PCS, and INFO. The main display area shows a 'BAT ID' field with a dropdown menu, a 'Switch the primary and secondary servers' button, and various real-time metrics: Voltage (0.0 V), Current (0.0 A), Power (0.000 kW), and Speed (0.00 km/h). Below these are tables for 'Max Cell Volt' and 'Min Cell Volt' across four modules (Module_1 to Module_4), each with C-B and F-B columns. A 'Status' section lists various components like MOSFET, Board, Heatsink, and COMPA, along with their operational states (e.g., Local: OFF, Charge: ON). At the bottom, there are four status indicators: PRE-CHG, DISCHARGE, CHARGE, and HEAT, each with a corresponding icon and a red 'OFF' label.

View internal information about a single battery module

View the parallel battery module information

7 Inspection, Cleaning and Maintenance

7.1 General Information

- The battery product is not fully charged. It is recommended that the installation be completed within 3 months after arrival;
- During the maintenance process, do not re-install the battery in the battery product. Otherwise, the performance of the battery will be reduced;
- It is forbidden to dismantle any battery in the battery product, and it is forbidden to dis- sect the battery;
- After the battery product is over-discharged, it is recommended to charge the battery within 48 hours. The battery product can also be charged in parallel. After the battery product is connected in parallel, the charger only needs to connect the output port of any product battery.
- Never attempt to open or dismantle the battery! The inside of the battery does not contain serviceable parts.
- Disconnect the Li-Ion battery from all loads and charging devices before performing cleaning and maintenance activities.
- Place the enclosed protective caps over the terminals before cleaning and maintenance activities to avoid the risk of contacting the terminals.
- All the battery terminals must be disconnected for maintenance.
- Please contact the supplier within 24 hours if there is something abnormal.
- Do not use cleaning solvents to clean battery.

7.2 Inspection

- Inspect for loose and/or damaged wiring and contacts, cracks, deformations, leakage, or damage of any other kind. If damage to the battery is found, it must be replaced. Do not attempt to charge or use a damaged battery. Do not touch the liquid from a ruptured battery.
- Regularly check the battery's state of charge. Lithium Iron Phosphate batteries will slowly self-discharge when not in use or whilst in storage.
- Consider replacing the battery with a new one if you note either of the following conditions:
 - The battery run time drops below 70% of the original run time.

-The battery charge time increases significantly.

7.3 Cleaning

If necessary, clean the Li-Ion battery with a soft, dry cloth. Never use liquids, solvents, or abrasives to clean the Li-Ion battery.

7.4 Maintenance

The Li-Ion battery is maintenance-free. Charge the battery to approximately > 80% of its capacity at least once every year to preserve the battery capacity.

8 Storage

- The battery product should be stored in a dry, cool, and cool environment;
- If the battery is stored for long time, it is required to charge them every six months, and the SOC should be no less than 50%.
- Generally, the maximum storage period at room temperature is 6 months. When the battery is stored over 6 months, it is recommended to check the battery voltage. If the volt age is higher than 51.2V, it can continue to store the battery. In addition, it is needed to check the voltage at least once a month until the voltage is lower than 51.2V. When the voltage of the battery is lower than 51.2V, it must to be charged according to the charging strategy.
- When the battery product is stored, the source of ignition or high temperature should be avoided and it should be kept away from explosive and flammable areas.
- If your batteries need to be charged or discharged in lead-acid mode, maintain a charge / discharge current of 0.2C within a temperature range of 5°C to 45°C.

9 Troubleshooting

To determine the status of the battery system, users must use additional battery status monitoring software to examine the protection mode. Refer to the installation manual about using the monitoring software. Once the user knows the protection mode, refer to the following sections for solutions.

Fault Type	Phenomenons	Possible Causes	Solutions
Information collection fails	The cell voltage sampling circuit is faulty. The cell temperature sampling circuit is faulty	The welding point for cell voltage sampling is loose or disconnected. The voltage sampling terminal is disconnected. The cell temperature sensor has failed.	Replace the collection line.
Electrochemical cell error	The voltage of the cell is low or unbalanced.	Due to large self-discharge, the cell over discharges to below 2.0V after long term storage. The cell is damaged by external factors, and short circuits, pinpricks, or crushing occur.	Replace the battery.
Over-voltage protection fails	The cell voltage is greater than 3.65 V in charging state. The battery voltage is greater than 58.4 V.	The busbar input voltage exceeds the normal value. Cells are not consistent. The capacity of some cells deteriorates too fast or the internal resistance of some cells is too high.	If the battery cannot be recovered due to protection against abnormality contact local engineers to rectify the fault.
Under voltage protection fails	The battery voltage is less than 44.8V. The minimum cell voltage is less than 2.8V	The mains power failure has lasted for a long time. Cells are not consistent. The capacity of some cells deteriorates too fast or the internal resistance of some cells is too high.	Same as above.
Charge or discharge high temperature protection fails	The maximum cell temperature is greater than 60°C	The battery ambient temperature is too high. There are abnormal heat sources around	Same as above.
Charge low temperature protection fails	The minimum cell temperature is less than 0°C	The battery ambient temperature is too low.	Same as above.
Discharge low temperature protection fails	The minimum cell temperature is less than -20°C	The battery ambient temperature is too low.	Same as above.

10 Environmental Disposal

Used batteries can not be disposed of as household waste. You are obliged to handle waste batteries, such as removal of privacy on product, and return them to designated or authorized recovery point according to applicable regulations and standards on waste battery disposal.



Attention:

- (1) Do not dispose of batteries and rechargeable batteries as domestic waste! You are legally obliged to return used batteries and rechargeable batteries.
- (2) Waste batteries may contain pollutants that can damage the environment or your health if improperly stored or handled.
- (3) Batteries also contain iron, lithium and other important raw materials, which can be recycled.

For more information, please visit <http://www.tommatech.de>.

Do not dispose of batteries as household waste!



Li-ion



11 Transportation Requirements

1. The battery products should be transported after packaging and during the transportation process. Severe vibration, impact, or extrusion should be prevented to prevent sun and rain. It can be transported using vehicles such as cars, trains, and ships.
2. Always check all applicable local, national, and international regulations before transporting a Lithium Iron Phosphate battery.
3. Transporting an end-of-life, damaged, or recalled battery may, in certain cases, be specially limited or prohibited.
4. The transport of the Li-Ion battery falls under hazard class UN3480, class 9. For transport over water, air and land, the battery falls within packaging group PI965 Section I. Use Class 9 Miscellaneous Dangerous Goods and UN Identification labels for transportation of lithium-ion batteries which are assigned Class 9. Refer to relevant transportation documents.



Class 9 Miscellaneous Dangerous Goods and UN Identification Label

12 Technical Specifications

Cell Chemistry		LiFePO ₄					
Module Energy (kWh)		5.12					
Module Nominal Voltage (V)		51.2					
Battery Module Name	Hightech Power S 5.3kWh LV AIO	Hightech Power S 10.2kWh LV AIO	Hightech Power S 15.3kWh LV AIO	Hightech Power S 20.4kWh LV AIO	Hightech Power S 25.6kWh LV AIO	Hightech Power S 30.7kWh LV AIO	
Battery Module Quantity	1(Min.)	2	3	4	5	6 (max)	
Battery Module Capacity (Ah)	100	200	300	400	500	600	
System Operating Voltage (V)		44.8~57.6					
System Energy (kWh)		5.12	10.24	15.36	20.48	25.6	30.72
System Usable Energy (kWh) ^[1]		5.12	10.24	15.36	20.48	25.6	30.72
Charge/Discharge Current (A)	Max. ^[2]	1LV BMS+1pack:100; 1LV BMS+2pack:200; 1LV BMS+3pack:250; 1LV BMS+4pack:250; 1LV BMS+5pack:250; 1LV BMS+6pack:250 (1 LV BMSis compatible with at least 1 battery and at most 6 batteries)					
	Peak(10s,25 °C)	1LV BMS+1pack:150; 1LV BMS+2pack:270; 1LV BMS+3pack:360; 1LV BMS+4pack:360; 1LV BMS+5pack:360; 1LV BMS+6pack:360 (1 LV BMSis compatible with at least 1 battery and at most 6 batteries)					
Operating Temperature		Charge: 0~55°C (-20°C~55°C when heating on) Discharge: -20°C~55°C					
Master LED Indicator		Battery module: 3LED (working, alarming, protecting)					
		Hightech Power S LV BMS module: 5LED(SOC:20%~100%)& 3LED (working, alarming, protecting)					
		Hightech Power S LV BMS AIO module:5LED(SOC:20%~100%)&2LED (working, alarming)					
Communication Port		CAN2.0, RS485					
Humidity		5%~95%					
Altitude (m)		≤3000					
IP Rating of Enclosure		IP65(after stacking)					
Hightech Power S LV BMS Dimension (W/D/H, mm)		720*255*240					
Hightech Power S LV BMS AIO Dimension (W/D/H, mm(without terminal))		720*255*240					

Battery Pack Dimension (W/D/H, mm) (without terminal)	720*255*300					
Base Dimension (W/D/H, mm) (without terminal)	720*255*68					
Hightech Power S LV BMS System Dimension (W/D/H, mm)	720*25 5*608	720*25 5*908	720*25 5*1208	720*255 *1508	720*255 *1808	720*25 5*2108
Hightech Power S LV BMS AIO System Dimension(W/D/H, mm)	720*25 5*1008	720*25 5*1308	720*25 5*1608	720*255 *1908	720*255 *2208	720*25 5*2508
Hightech Power S LV BMS Weight (kg)	18.5					
Hightech Power S LV BMS AIO Weight (kg)	18.5					
Battery Pack Weight (kg)	53					
Base Weight (kg)	6.5					
System Weight (kg)	53*m+25					
Installation	Floor-Mounted					
Storage Temperature (°C)	0°C ~ 35°C					
Recommend Depth of Discharge	100%					
Cycle Life	≥6000(25°C±2°C, 0.5C/0.5C,90%DOD,70%EOL)					
Certification	UN38.3, IEC62619, UN+IEC6100+1EC62619+VDE4105					

[1]DC Usable Energy, test conditions: 100% DOD, 0.5C charge & discharge at 25°C. System usable energy may vary due to system configuration parameters.

[2]The current is affected by temperature and SOC.

[3] m: the number of battery packs in per cluster, $1 \leq m \leq 6$. See the picture.

Hightech Power S XkWh LV AIO

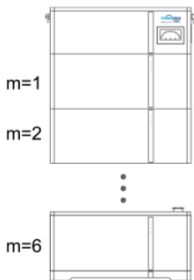

Hightech Power S LV BMS AIO

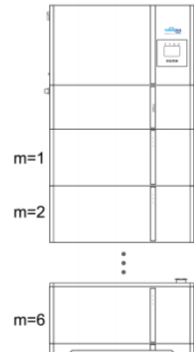

13 EU Declaration of Conformity



TommaTech GmbH confirms herewith that the products described in this document are in compliance with the fundamental requirements and other relevant provisions of the above mentioned directives.

Annex I-Manufacturer Self Declaration

The electrochemical performance and durability parameters

Product Model: Hightech Power S 5.1kWh LV AIO

Parameters	Value	Test method
Rated Capacity	100Ah	Actual measurement@25°C±3°C ①0.5C charge ②rest30min ③0.5C discharge
Capacity Fading	6000 Cycles, fade ≤30%	Actual measurement@25°C±3°C ①0.5C charge ②rest30min ③0.5C discharge, 90%DOD
Power	2560W	@25°C±3°C charge and discharge@ 20%~80%SOC
Power Fading	10 years,fade ≤30%	/
Internal Resistance	≤10mΩ	Actual measurement@25°C±3°C ①0.5C CC 3.65V,CV 0.05C, Cut ②Discharge to 50%SOC,rest 3h, V0 ③discharge 0.5C,10s, V2 ④(V0-V1)/50
Increased internal Resistance	10 years, Increased ≤30%	/
Energy efficiency	94%	Actual measurement@25°C±3°C ①0.5C CC 3.65V ②Discharge to 2.5V, E0 ③0.5C CC 3.65V, E1 ④E0/E1
Energy efficiency Fading	10 years, fade ≤3%	/
Cycle Life	≥6000@70%SOH, 10 years	Actual measurement@25°C±3°C ①0.5C charge ②rest30min ③0.5C discharge, 90%DOD



Zeppelinstrasse 14 - 85748 Garching München/Germany

Telefon: +49 89 1250 36 860

E-mail: mail@tommatech.de