

CW Enerji

CW  Enerji

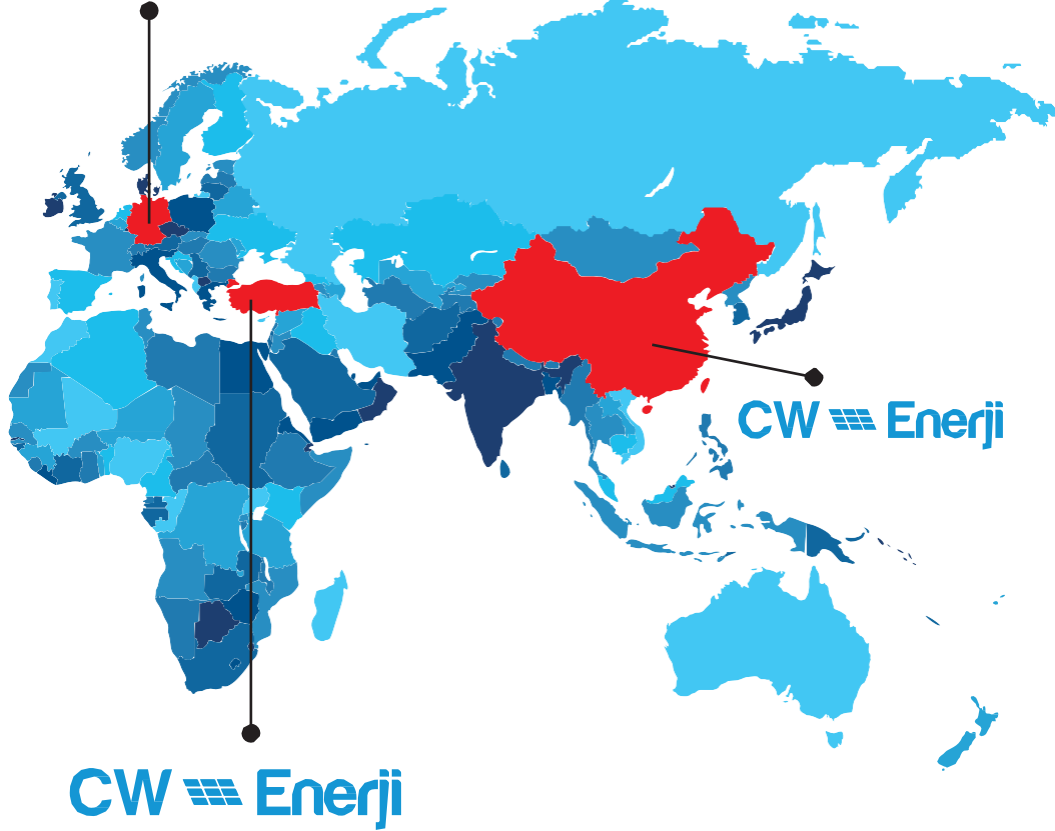

CW  Enerji

ADDRESS IN TURKEY

242 229 00 54 / +90 242 229 60 54

F:+90 242 229 00 74

www.cw-enerji.com - info@cw-enerji.com

Antalya Organize San. Bölgesi 1. Kısım

Atatürk Blv. No:20 Dösemealtı - Antalya / TÜRKİYE

INSTALLATION MANUAL



CONTENTS

1. INTRODUCTION	4
2. CODES AND REGULATIONS	4
3. GENERAL.....	4
3.1 Product Identification	5
3.2 Conventional Safety	5
3.3 Electrical Performance Safety.....	5
3.4 Operating Safety	6
3.5 Fire Safety.....	6
4. INSTALLATION CONDITION	7
4.1 Installation Position and Working Environment.....	7
4.2 Tilt Angle Selection.....	7
5. MECHANICAL INSTALLATION	8
5.1 Conventional Requirement	8
5.2 Installation Method.....	9
5.2.1 Modules installed with mounting holes	9
5.2.2 Modules Installed with clamp.....	9
5.2.3 Description of the installation position	11
6. ELECTRICAL INSTALLATION	12
6.1 Electrical Property	12
Cables and Wiring	13
6.2 Connectors.....	13
6.3 Bypass Diodes	14
7. GROUNDING	14
7.1 Grounding by Using Grounded Clamp	14
7.2 Grounding by Using Unused Mounting Hole	15
7.3 Additional Third-Party Grounding Devices	16
8. OPERATION AND MAINTENANCE	17
8.1 Cleaning.....	17
8.2 Visual Inspection of Modules	18
8.3 Inspection of connector and cable.....	18
9. APPLICABLE PRODUCTS	19

1. INTRODUCTION

CW Enerji Mühendislik Ticaret ve Sanayi Co. Ltd. is a hi-tech company engaged in the development, research, production, sales and service of crystalline silicon wafers, solar cells, solar panels, and photovoltaic systems. (Hereafter referred to as “CW Enerji”)

CW Enerji has in the photovoltaic field stable and reliable partnerships in Europe and in Far East that value quality and good production.

Purchasing of products as well as turnkey projects we will support you with our strong and experienced team with a wide product range and variety of methods of procedure. Our mission is a personal best quality and customer satisfaction.

2. CODES AND REGULATIONS

The mechanical and electrical installation of PV systems should be performed in accordance with all applicable codes, including electrical codes, building codes and electric utility interconnect requirements.

Such requirements may vary for mounting location, such as building rooftop or motor vehicle applications.

Requirements may also vary with system voltage, and for DC or AC application. Contact local authorities for governing regulations.

3. GENERAL

The parts of our solar panels are indicated in the cross-section figure below:

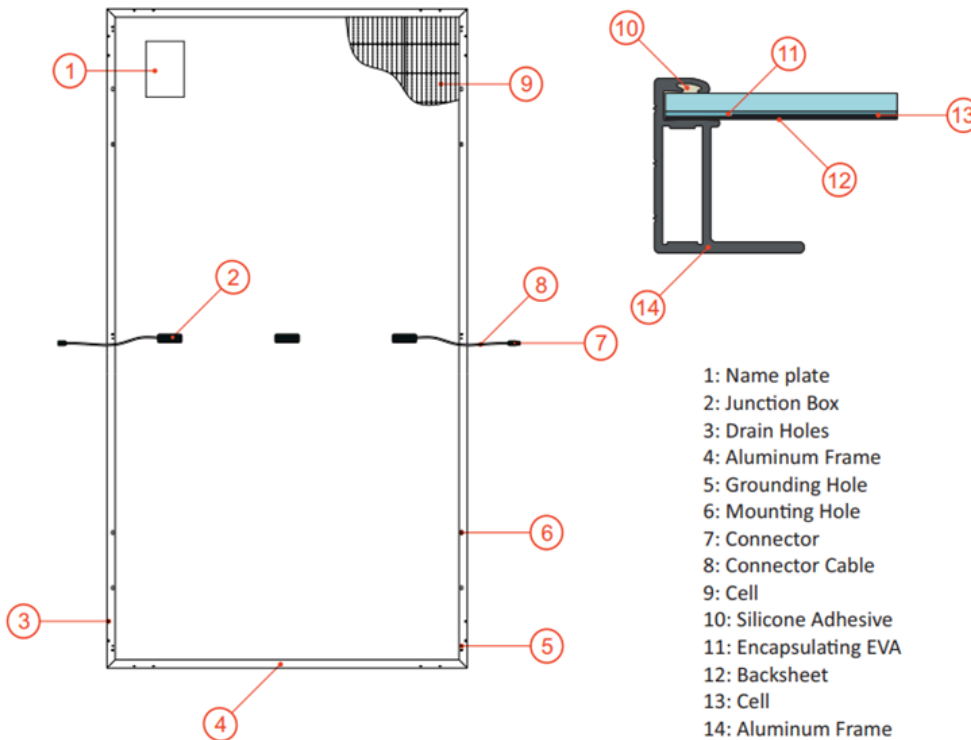

Figure 1: Modules components and cross-section of the laminated assembly

3.1 Product Identification

Each module has three labels providing the following information:

1. Nameplate: describes the product type; Peak power, Max. power current, Max. power voltage, open circuit voltage, short circuit current, all as measured under standard test conditions; Certification marks, the maximum system voltage etc.
2. Current Classes. Solar panels are divided into three classes according to the maximum power current: 1, 2 or 3 (3 means the highest current). This class is marked as a number on the pallets of the solar panels. To achieve an optimal performance of the solar panels, it is recommended to only connect solar panels with the same current class in a string.
3. Barcode: Each individual module has a unique serial number. The serial number has 12 digits. From 1st to 2nd digits are the solar cell size code, and the 3rd and 4th are the corrected year code, from 5th and 6th are the corrected month codes, from 7th is the optional serial number and from 8th and 12th are the serial number of a module. For example, 133414000001 means the Module was assembled and tested in the January of 2021. It is permanently attached to the interior of the Modules and is visible from the top front of the Module. This barcode is inserted prior to laminating. In addition, you can find a same barcode beside the nameplate and two sides of frame surfaces.

3.2 Conventional Safety

CW Enerji Modules are designed to meet the requirements of IEC 61215 and IEC 61730, PV module classification: Class II

Modules rated for use in this PV module classification may be used in system operating at greater than 50V DC or 240W, where general contact access is anticipated. Modules qualified for safety through IEC 61730-1 and IEC 61730-2 and within this PV module classification are considered to meet the requirements for safety class II equipment.

When Modules are mounted on rooftops, the roof must have a fire-resistant covering suitable for this application. Rooftop PV systems should only be installed on rooftop that can handle the additional weighted load of PV system components, including Modules, by a certified building specialist or engineer and have a formal structure of the complete analysis result.

For your safety, do not attempt to work on a rooftop until safety precautions have been identified and taken including without limitation fall protection measures, ladders or stairways, and personal protective equipment.

For your safety, do not install or handle Modules under adverse conditions, including without limitation strong or gusty winds, and wet or frosted roof surfaces.

3.3 Electrical Performance Safety

Photovoltaic Modules can produce DC electricity when exposed to light and therefore can produce an electrical shock or burn. DC voltage of 30 Volts or higher is potentially lethal.

Modules produce voltage even when not connected to an electrical circuit or load. Please use insulated tools and rubber gloves when working with Modules in sunlight.

Modules have no on/off switch. Modules can be rendered inoperative only by removing them from sunlight, or by fully covering their front surface with cloth, cardboard, or other completely opaque material, or by working with Modules face down on a smooth, flat surface.

In order to avoid arcs and electrical shock, please do not disconnect electrical connections under load. Faulty connections can also result in arcs and electrical shock. So please keep connectors dry and clean, and ensure that they are in proper working condition. Never insert metal objects into the connector or modify them in any way to secure an electrical connection.

Also, to avoid the sand or water vapor entering which may cause the connection and safety issue, the modules need to be installed and connected to the combiner box once they are taken out from the carton box; keep the connectors dry and clean during the installing. Note that the pollution from sand, dust and water will result in arcs and electrical shock of connectors.

Reflection from snow or water can increase sunlight and therefore boost current and power. In addition, colder temperatures can substantially increase voltage and power.

If the glass or other material is damaged, please wear personal protection equipment and separated the Modules from the circuit.

Work only under dry conditions and use only dry tools. Do not handle Modules when they are wet unless wearing appropriate protective equipment. If you need to clean the Modules, please follow the cleaning requirements mentioned in the manual.

3.4 Operating Safety

Do not open packages of CW Enerji modules during transportation and storing until they are ready to be installed.

At the same time please protect the package from damage. Do not make the pallets of modules falling over directly.

Do not exceed the maximum height of pallets to be stacked, as indicated on the pallet packaging. Store pallets in a ventilated, rain-proof, and dry location until the modules are ready to be unpacked. Do not lift the modules by grasping the module's junction box or electrical cable under any condition.

Do not stand or step on the modules.

Do not drop the modules on another module.

Do not place any heavy objects on the modules to avoid damaging the glasses.

Be cautious when setting the modules down on to a surface, especially on the corner of the Modules. Inappropriate transportation and installation may break the Modules.

Do not attempt to disassemble the Modules, and do not remove any attached nameplates or components from the modules.

Do not apply paint or adhesive to the Modules top surface.

To avoid damage to the backsheet, do not scratch or hit the backsheet.

Do not drill holes in the frame. This may compromise the frame strength and cause corrosion of the frame.

Do not scratch the anodized coating of the frame (except for bonding connection). It may cause corrosion of the frame or compromise the frame strength.

Do not attempt to repair the modules with damaged glass or backsheet.

3.5 Fire Safety

Consult your local authority for guidelines and requirements for building or structural fire safety. CW Enerji Modules have been listed as Class C according to IEC 61730-2 standard.

For roof installations, Modules should be mounted over a fire-resistant covering suitable for this application, with adequate ventilation between the Modules backsheet and the mounting surface. Roof constructions and installations may affect the fire safety of building. Improper installation may create hazards in the event of a fire.

Consult your local authority for guidelines and requirements for building or structural fire safety. CW Enerji modules are listed as Class C according to the IEC 61730-2 standard.

For roof installations, Solar panels should be mounted over a fire-resistant covering suitable for this application, with adequate ventilation between the modules backsheet and the mounting surface. Roof constructions and installations may affect the fire safety of building. Improper installation may create hazards in the event of a fire.

Solar panels should not be installed on structures and products made of transparent plastic, plastic and similar materials that are resistant to fire risk and not protected.

In order to maintain the fire class rating, the distance between the modules frame surface and the roof surface shall be at least 8 cm.

Regulations, communiqués, decrees, specifications, etc., put into effect by the relevant official institutions and organizations in the region where the installation will take place. Appropriate components such as fuses, circuit breakers, surge arresters and grounding connectors must be used to meet the requirements specified in all legislation. Any string or optimizer connector to be connected with the solar panel connector must be the same brand and model as the connector on the solar panel.

Do not install solar panels in places where flammable-explosive chemical products, gases and similar products can be found.

Panels that have not been installed in accordance with these standards and conditions will be out of warranty, the installation will be installed contrary to the installation manual, and the manufacturer will not be responsible for any risks or problems that may occur. In this context, the manufacturer does not have any responsibility, including compensation for damages, for any use contrary to the installation and assembly manual and for the consequences of such use.

4. INSTALLATION CONDITION

4.1 Installation Position and Working Environment

CW Enerji Modules are intended for use in terrestrial applications only-no for outer space use. Do not use mirrors or other magnifiers to concentrate sunlight onto the Modules.

Modules must be mounted on appropriate mounting structures positioned on suitable buildings, the ground, or other structures suitable for Modules (e.g., carports, building facades or PI/ trackers). Modules must not be installed in locations where they could be submerged in water.

The recommended ambient temperature should be within -20°C (-4°F) to 46°C (115°F). The temperature limits are defined as the monthly average high and low of the installation site. The limit operating temperature should be -40°C (-40°F) and 85°C (185°F).

Ensure Modules are not subject to wind or snow loads exceeding the maximum permissible loads. The Modules should be installed in a location where there is no shading throughout the year. Ensure there is no obstacle to block light near the installation site.

Lightning protection is recommended for PV systems that are to be installed in locations with high probability of lightning strikes.

Do not use Modules near equipment or in locations where flammable gasses may be generated or collected.

This module application can be made maximum 2000m altitude.

Modules must not be installed nor operated in areas where hail, snow, sand, dust, air pollution, soot, etc., are excessive. Modules must not be sited in locations where aggressive substances such as salt, salt mist, saltwater, chemically active vapors, acid rain, any other type of corrosive agent, could affect the safety and/ or performance of the Modules.

Please adopt appropriate measures to ensure the performance and safety of the Modules when they are installed or operated in the areas where produces heavy snow, extremely cold, strong wind, or near the island or desert where is prone to produce salt fog, or near water.

4.2 Tilt Angle Selection

The tilt angle of the Modules is measured between the surface of the Modules and a horizontal ground surface. The Modules generates maximum power output when it faces the sun directly.

In the northern hemisphere, Modules should typically face south, and in the southern hemisphere, Modules should typically face north.

For detailed information on the best installation angle, please refer to standard solar photovoltaic installation guides or consult a reputable solar installer or systems integrator.

Dust building up on the surface of the Modules can impair with Modules performance. CW Enerji recommends installing the Modules with a tilt angle of at least 10 degrees, making it easier for dust to be washed off by rain.

5. MECHANICAL INSTALLATION

5.1 Conventional Requirement

Ensure that the installation method and supporting system of Modules is strong enough to make the Modules to able to withstand all the load conditions. The Installer must provide the guarantee. The installation supporting system must be tested by the third-party organization with the analysis ability of Static Mechanical, according to the local national or international standards such as DIN1055 or equivalent standards.

The Modules mounting structure must be made of durable, corrosion-resistant, and UV-resistant material.

Modules must be securely attached to the mounting structure.

In regions with heavy snowfall in winter, select the height of the mounting system. So that the lowest edge of the Modules is not covered by snow for any length of time. In addition, ensure that the lowest portion of the Modules is placed high enough so that it is not shaded by plants or trees or damaged by flying sand.

When the Modules are supported parallel to the surface of the building wall or roof, a minimum clearance of 10 mm between the Modules frame and the surface of the wall or the roof is required to allow air to circulate behind the Modules and to prevent wiring damage.

Do not attempt to drill holes in the glass surface and the Modules frames of the Modules.

Before installing Modules on a roof, ensure that the roof construction is suitable. In addition, any roof penetration required to mount the Modules must be properly sealed to prevent leaks.

Observe the linear thermal expansion of the Modules frames, must ensure that the minimum distance between neighboring frames is 10 mm.

Always keep the backsheet of the panel free from foreign objects or structural elements, which could come into contact with the panel, especially when the panel is under mechanical load.

Modules have been certified for a maximum static load on the back-side of 2400 Pa (i.e. wind load) and a maximum static load on the front side of 2400 Pa (i.e. wind and snow load), depending on the Modules type (please refer to Figure 4 for detailed installation method). These load values are maximum. The design load for 2400 Pa is 1600 Pa. The safety factor is 1,5.

The mounting method must not result in the direct contact of dissimilar metals with the aluminum frame of the Modules that will result in galvanic corrosion.

Modules can be mounted in landscape or portrait orientation.

5.2 Installation Method

Modules can be installed on the frame using mounting holes, clamps, or an insertion system. Modules must be installed according to the following examples and recommendation. If not mounting the Modules according to these instructions, please in advance consult CW Enerji and must be approved by CW Enerji, otherwise may damage modules, and void the warranty.

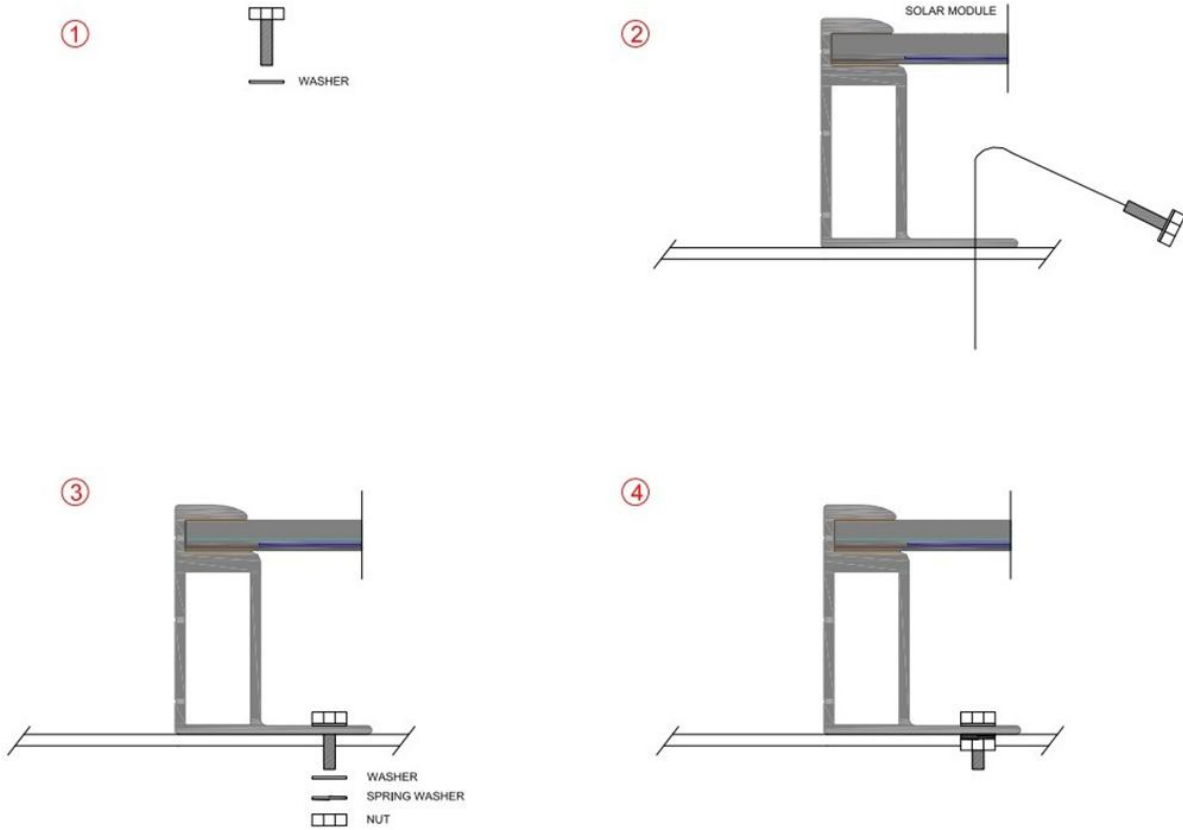

Figure 2: Mounting Details

5.2.1 Modules installed with mounting holes

Modules should be bolted to support structures through mounting holes located in the frame's back flanges. Refer to what is shown in Figure 2 (Mounting Details).

5.2.2 Modules Installed with clamp

Modules should be mounted using specialized clamps as shown in Figure 3.

A) Modules should be attached on a supporting structure rail by metal clamps. It is recommended to use the clamps under the following condition or approved by system installation:

- Width: Clamp A no less than 38mm, Clamp B no less than 50mm,
- Thickness: No less than 3mm,
- Material: Aluminium Alloy,
- Bolt: M8.

B) Bolt torque requirement: 12-16 Nm

C) The Modules clamps must not contact the front glass or deform the frame in any way, the contact area of damp with the front of frame must be smooth, otherwise maybe damage the frame bring about the modules broken. Avoid shading effects from the Modules clamps. Drainage holes on the Modules frame must not be closed or obscured.

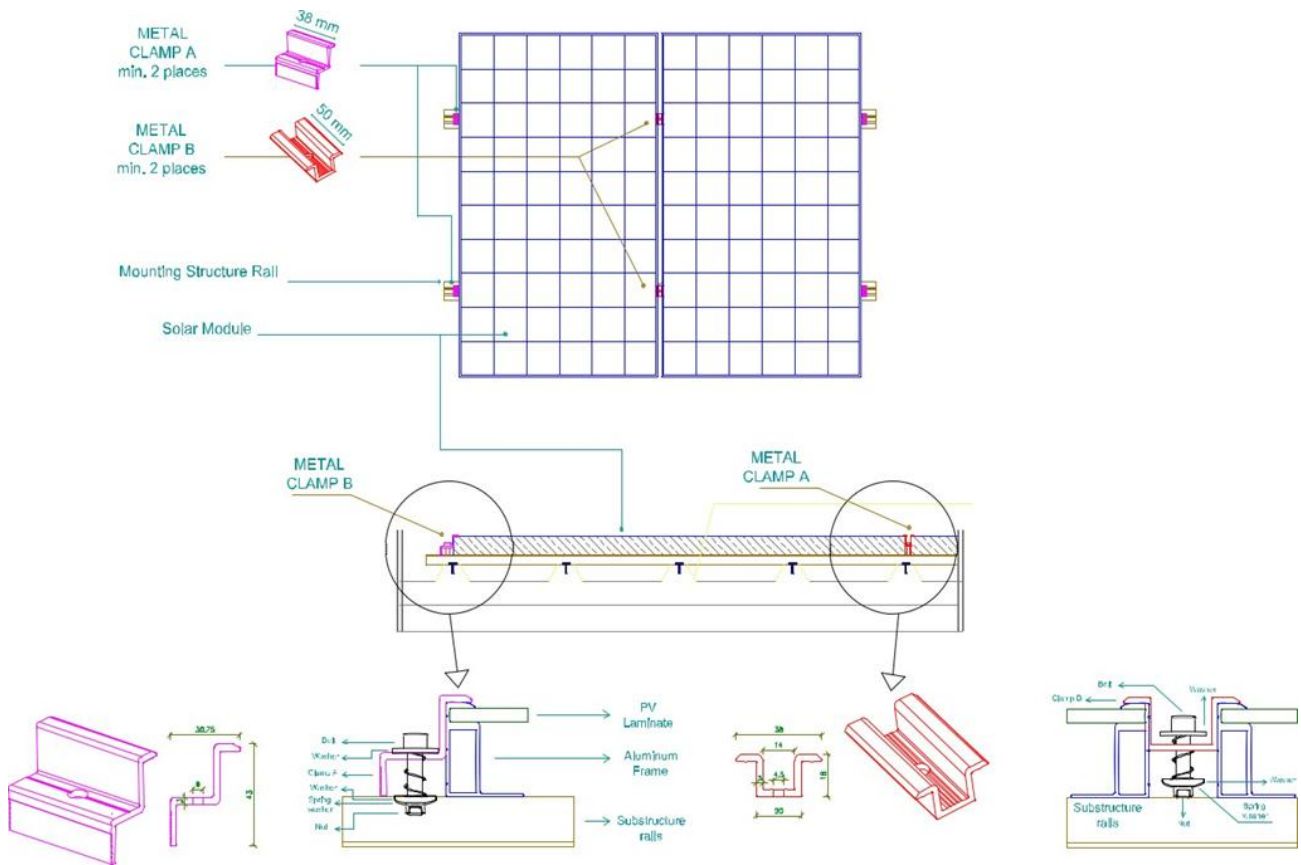

Figure 3: Clamp Details (Units: mm)

5.3 Description of the installation position

The low/normal level of load condition is applicable to the installation in most of environmental conditions: the maximum static test load on the back of the Modules is 2400 Pa (i.e., wind load), and the maximum static test load on the front of the Modules is 2400 Pa (i.e., wind and snow load).

The high level of load condition is applicable to the installation in harsher environmental conditions such as storm, heavy snow, etc. the maximum static test load on the back of the Modules is 2400 Pa (i.e., wind load) and the maximum static test load on the front of the Modules is 2400 Pa (i.e., wind and snow load), depending on the pressure level that it would endure according to IEC standard.

For the dynamic loads, such as wind, the safety factor needs to be increased by 3 times. It means that the maximum dynamic load is 800 Pa when the wind speed is less than 130 km/h.

The mechanical load tests carried out within the certification were made in the form of a red marked assembly. It must be installed in this way for warranty coverage.

(Design load: 1600 Pa for wind load, 2400 Pa for snow load, safety factor $\gamma_m = 1.5$)

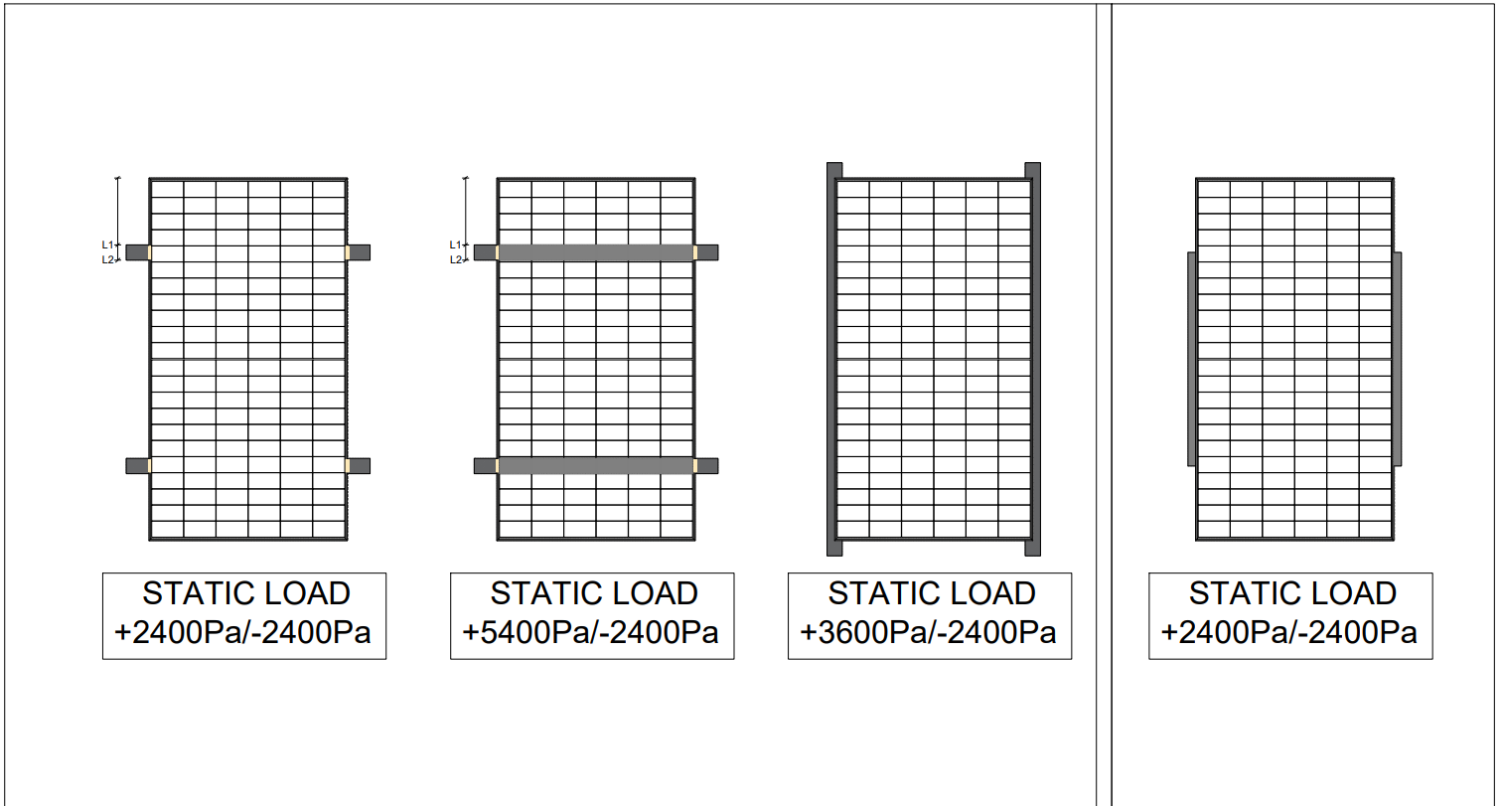

Figure 4: Installation Methods

The L_1 and L_2 values in Figure 4, represent the mounting distance depending on the model type. In the "9. APPLICABLE PRODUCTS" section, the values are shown in the table.

6. ELECTRICAL INSTALLATION

6.1 Electrical Property

Rated electrical characteristics such as I_{sc} , V_{oc} and P_{max} are measured within $\pm 3\%$ of Measurement uncertainty at Standard Test Conditions. Standard Test Conditions: 1000 W/m² irradiance, 25°C Cell Temperature and 1.5 Air Mass.

Under normal conditions, photovoltaic Modules may produce higher current and/or voltage than reported at Standard Test Conditions. Accordingly, the values of short circuit current, I_{sc} , and open circuit voltage, V_{oc} , marked on Modules should be multiplied by a factor of 1.25 when determining component voltage ratings, conductor capacities, fusing sizes, and size of controls connected to the solar panels.

Voltages are additive when Modules are connected directly in series, and Modules currents are additive when Modules are connected directly in parallel, as illustrated in Figure 5.

The maximum number of stringing is calculated according to the voltage of the junction box of the panels, the NOCT value of the panel, the DC input voltage of the inverter to be used, and the ambient temperature of the location of the plant. Modules with different electrical characteristics should not be connected directly in series.

$$\text{System Voltage} \geq N * \text{Voc} [1 + \text{TCVoc} * (\text{Tmin} - 25)]$$

N = Number of panels in the series

Voc = Open Circuit Voltage (data on product label or datasheet)

TCVoc = Temperature coefficient of open circuit voltage (data on product label or datasheet)

Tmin = Minimum ambient temperature

Series Wiring

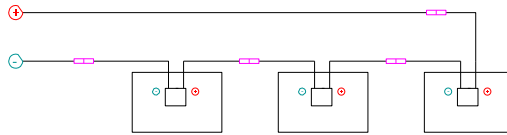

Parallel Wiring

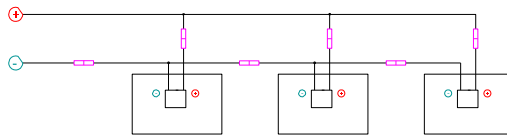

Series Wiring and Parallel Wiring

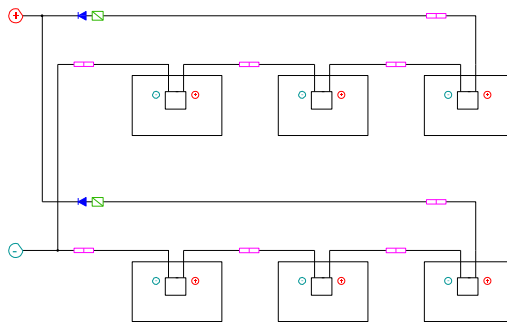

← Diodes

— Connector

— Overcurrent protection

Figure 5: Electrical diagrams of series and parallel wiring

The maximum number of Modules that can be connected in a series string must be calculated in accordance with applicable regulations in such a way that the specified maximum system (The maximum system voltage of CW Enerji Modules is DC 1000V / DC 1500V according to the safety appraisal of the IEC61730) of the modules and all other electrical DC components will not be exceeded in open-circuit operation at the lowest temperature expected at the PV system location.

An appropriately rated over-current protection device must be used when the reverse current could exceed the value of the maximum fuse rating of the Modules. An over-current protection device is required for each series string if more than two series strings are connected in parallel, as illustrated in Figure 5.

6.2 Cables and Wiring

These junction boxes have been designed to be easily interconnected in series for their well-connected cable and the connector with IP67 protection grade. Each Modules has two single-conductor wires, one positive and one negative, which are pre-wired inside the junction box. The connectors at the opposite end of these wires allow easy series connection of adjacent Modules by firmly inserting the positive connector of a Module into the negative connector of an adjacent Module until the connector is fully seated.

Use field wiring with suitable cross-sectional areas that are approved for use at the maximum short-circuit current of the Modules. CW Enerji recommends installers use only sunlight resistant cables qualified for direct current (DC) wiring in PV systems. The minimum wire size should be 4mm². For example, a solar cable according to the specifications on the next page is recommended.

Testing Standard	Wire size	Temperature Rating
TÜV 2 PfG 11694	4mm ²	-40°C to +90°C

The cable of the junction box is in Figure 6 below.

L: Cable Length

L for CW Enerji standard module is 1000/1200 mm, L for half-cut module is 300/1200 mm and L for bifacial module is 300/1200 mm. L for special modules may vary depending on the situation. Please consider the cable length before designing the wiring layout.



Figure 6: Junction Box Cable

Cables should be fixed to the mounting structure in such a way that mechanical damage of the cable and/or the Modules is avoided. Do not apply stress to the cables. For fixing, use appropriate means, such as sunlight resistant cable ties and/or wire management clips specifically designed to attach to the Modules frame. While the cables are sunlight resistant and waterproof, where possible, avoid direct sunlight exposure and water immersion of the cables.

6.3 Connectors

Keep connectors dry and clean and ensure that connector caps are hand tight before connecting the Modules. Do not attempt to make an electrical connection with wet, soiled, or otherwise faulty connectors. Avoid sunlight exposure and water immersion of the connectors. Avoid allowing connectors to rest on the ground.

Faulty connections can result in arcs and electrical shock. Check that all electrical connections are securely fastened. Make sure that all locking connectors are fully engaged and locked. The connector

can be locked in conformity with NEC 2011 by an integrated snap-in lock for maximum dependability, and can be unlocked only with the tool PV-MS-PLS. Only the same type of connectors can be used for installation.

6.4 Bypass Diodes

The junction boxes used with CW Enerji Modules contain bypass diodes wired in parallel with the PV cell strings. In the case of partial shading, the diodes bypass the current generated by the nonshaded cells, thereby limiting Modules heating and performance losses. Bypass diodes are not over-current protection devices.

Bypass diodes divert current from the cell strings in the event of partial shading.

In the event of a known or suspected diode failure, installers or maintenance providers should contact CW Enerji. Never attempt to open the junction box by yourself.

7. GROUNDING

CW Enerji Modules use an anodic oxidized aluminum frame to resist corrosion. So, the frame of Modules must be connected to the equipment bonding conductor to prevent thunder and static injury.

The bonding device must fully contact with the inside of the aluminum alloy and must penetrate the surface of the frame oxidation film.

Please do not drill any additional bonding hole on the frame of the Modules.

For optimal performance, CW Enerji recommend the DC cathode of the Modules array is connected to ground, Failure to comply with this requirement may reduce the performance of the system.

The bonding method must not result in direct contact of dissimilar metals with the aluminum frame of the Modules that will result in galvanic corrosion.

The frame rails have pre-drilled holes marked with a bonding sign. These holes should be used for bonding purposes and must not be used for mounting the Modules.

The following bonding methods are available.

7.1 Grounding by Using Grounded Clamp

There is a bonding hole with 4.2 mm diameter on the edge side closer to the middle of the back frame of the Modules. The middle line of the bonding mark is overlapped with the bonding hole, and the direction is same as the longer frame.

The bonding between Modules must be approved by qualified electrician. And the bonding device must be produced by qualified electrical manufacture. The recommended twist torque value is 2.3 N.m. A copper core in size of 12 AWG can be used as bonding clamp. The copper wire should not be compressed during the installation.

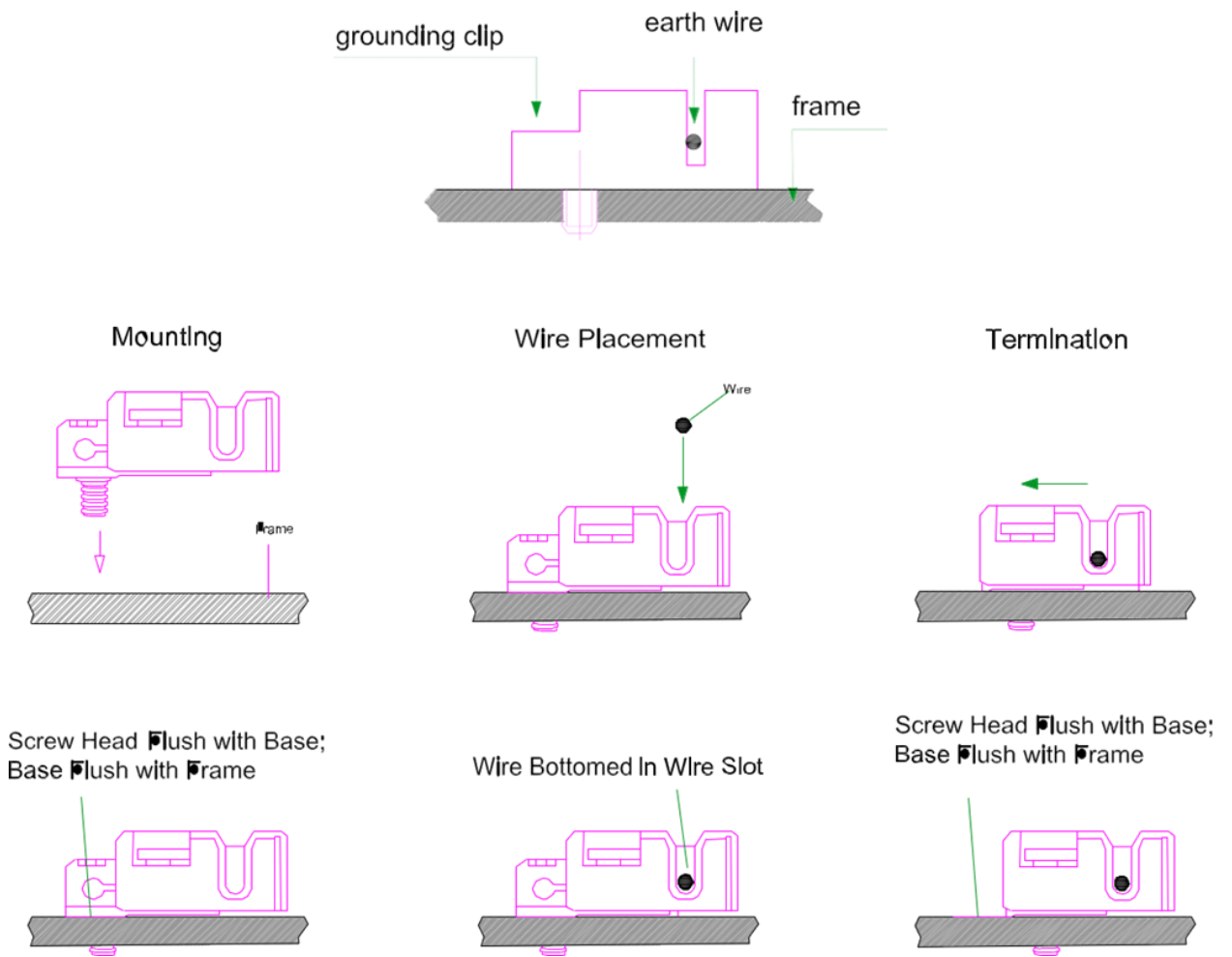

Figure 7: Installation Methods

7.2. Bonding by Using Unused Mounting Hole

The existing Mounting holes which have not been used can be used for bonding.

- Direct the bonding clamp to the mounting hole on the frame. Thread the bonding clamp and the frame with bonding bolt.
- Put the toothed gasket into the other side, than tighten and lock the nut. The recommended torque of locking the nut is 2.0 Nm-2.2 Nm.
- Thread the bonding clamp with bonding wire. The material and size of bonding wire should meet the relevant requirements of the national, regional, and local rule, law, and standard.
- Finish the mounting with tightening the binding bolt of the bonding wire

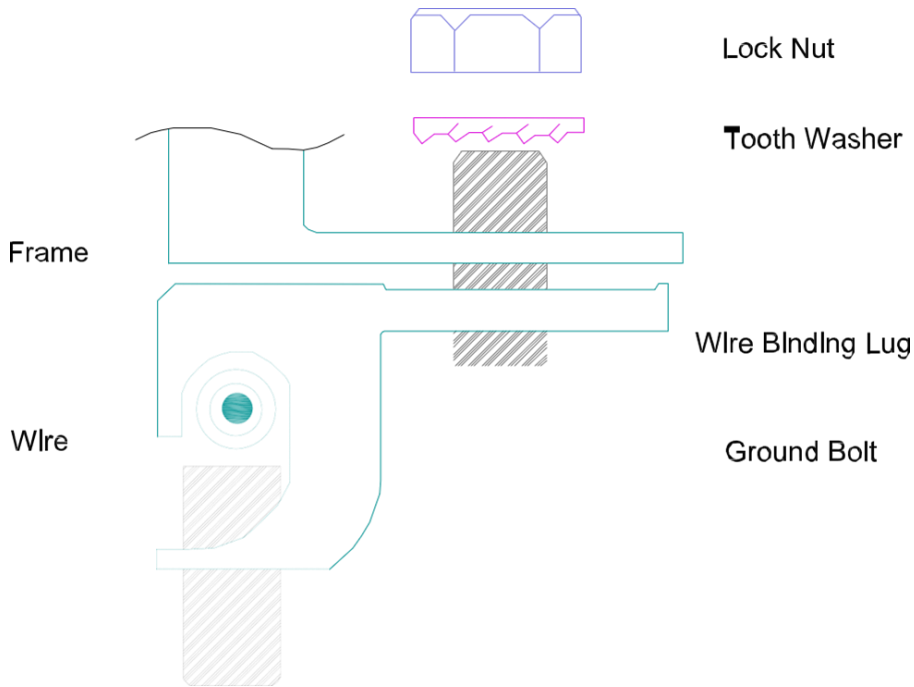

Figure 8: Installation Methods

7.3 Additional Third-Party Bonding Devices

CW Enerji Modules can be grounded using third-party bonding devices so long as they are certified for bonding Modules and the devices are installed according to the manufacturer's specified instructions.

8. OPERATION AND MAINTENANCE

It is required to perform regular inspection and maintenance of the Modules, especially within warranty scope. It is the user's responsibility to report to the supplier regarding the damages found within 2 weeks.

8.1 Cleaning

The dust accumulated on the front transparent substrate may reduce the power output and may even cause regional hot-spot effect. The industrial effluents or bird drops may be serious, and the extent of the severity depends on the transparency of the foreign objects. It is usually not dangerous for the accumulated dust to reduce the sunshine, because the light intensity is still homogeneous, and the power reduction is not usually obvious.

When Modules are working, there should not be environmental influence factors to cast shadows and cover part or even all the Modules, such as other Modules, system support, bird drops and a lot of dust, clay, or plant and so on, these may distinctly reduce the power output. CW Enerji advises that there should be no obstructed object over the Modules surface at any time.

The frequency of cleaning depends on dirt accumulation speed. In normal situations, rainwater will clean the module surface and reduce the cleaning frequency. It is suggested to use damp clean water sponge or soft cloth to wipe the glass surface. In any case, do not use acid and alkaline detergents to clean the solar panels.

***Water Type:**

Deionized (DI) Water: Deionized water, free from minerals, does not leave stains or residues after cleaning, which increases the efficiency of the panels.

***pH Value:**

Range: Should be between 6.5 and 8.5. This range provides effective cleaning without damaging the panel surfaces.

***Water Hardness:**

Total Hardness: Should be below 75 mg/L. The calcium content should not exceed 75 mg/L. This prevents mineral buildup and stain formation.

***Water Temperature:**

The water temperature should not differ by more than 20°C from the panel surface temperature. This reduces the risk of thermal shock and maintains panel integrity.

***Chemical Content:**

Acidic or alkaline detergents should not be used.

***Water Pressure:**

The water pressure used during cleaning should not exceed 35 bar (500 psi). Excessive pressure may damage the panel surface.

In order to avoid potential risk of electrical shock or burn, CW Enerji suggests cleaning the solar panels during early morning or in the evening with less solar irradiation and lower surface temperature. In order to avoid potential risk of electrical shock, do not try to clean the solar panels with glass damages or exposed wires.

8.2 Visual Inspection of Modules

Inspect the Modules visually to find whether there are appearance defects, the following need particularly special attention:

A) Whether the glass is broken,

B) Corrosion along the cells' busbar.

The corrosion is caused by the dampness infiltrated into the Modules because that the surface encapsulation materials are damaged during the installation or transportation.

C) Whether there is burning vestige on the backsheet.

D) Check PV solar panels for signs of aging including rodent damage, weather damage, connection tightness, corrosion, and grounding condition.

E) Check for any shape objects in contact with PV solar panels' surface

F) Check for any obstacles shielding the PV solar panels

G) Check for any loose or damage screws between the solar panels and brackets. If so, adjust or fix them on time.

8.3 Inspection of connector and cable

It is suggested to carry out the following preventive inspection once every 6 months:

- A) Check connector sealings and cable connections.
- B) Look for gaps on the sealant of the terminal box and confirm whether it is cracking

9. APPLICABLE PRODUCTS

GRUP	MODEL	HÜCRE TİPİ	GÜÇ ARALIĞI (5W ARA İLE)	HÜCRE SAYISI	PANEL BOYUTU (mm)	MONTAJ MESAFESİ ARALIĞI (mm) [L ₂ -L ₁]
GROUP 1	CWT60P	POLY	265W-285W	60 PCS FULL CELL	1648*995*35	280-380 mm
GROUP 2	CWT72P	POLY	320W-340W	72 PCS FULL CELL	1959*995*40	330-430 mm
GROUP 3	CWT60PM	PERC MONO	310W-335W	60 PCS FULL CELL	1668*1007*35	280-380 mm
GROUP 4	CWT72PM	PERC MONO	375W-400W	72 PCS FULL CELL	1984*1007*40	330-430 mm
GROUP 5	CWT120PM-HC	PERC MONO MULTI BUSBAR	360W-380W	120 PCS HALF-CUT CELL	1756*1039*35	300-400 mm
GROUP 6	CWT144PM-HC	PERC MONO MULTI BUSBAR	435W-455W	144 PCS HALF-CUT CELL	2095*1039*40	350-450 mm
GROUP 7	CWT108PM10	PERC MONO MULTI BUSBAR	395W-410W	108 PCS HALF-CUT CELL	1722*1134*35	280-380 mm
GROUP 8	CWT108PMB10	PERC MONO BIFACIAL	395W-410W	108 PCS HALF-CUT CELL	1722*1134*35	280-380 mm
GROUP 9	CWT108PMFB10	PERC MONO FULLBLACK	395W-410W	108 PCS HALF-CUT CELL	1722*1134*35	280-380 mm
GROUP 10	CWT144PM10	PERC MONO MULTI BUSBAR	530W-550W	144 PCS HALF-CUT CELL	2278*1134*35	390-490 mm
GROUP 11	CWT144PMB10	PERC MONO BIFACIAL	530W-550W	144 PCS HALF-CUT CELL	2278*1134*35	390-490 mm
GROUP 12	CWT144PMFB10	PERC MONO FULLBLACK	530W-550W	144 PCS HALF-CUT CELL	2278*1134*35	390-490 mm
GROUP 13	CWT156PM10	PERC MONO MULTI BUSBAR	575W-595W	156 PCS HALF-CUT CELL	2438*1135*35	420-520 mm
GROUP 14	CWT156PMB10	PERC MONO BIFACIAL	575W-595W	156 PCS HALF-CUT CELL	2438*1135*35	420-520 mm
GROUP 15	CWT156PMFB10	PERC MONO FULLBLACK	575W-595W	156 PCS HALF-CUT CELL	2438*1135*35	420-520 mm
GROUP 16	CWT108PM12	PERC MONO MULTI BUSBAR	530W-550W	108 PCS HALF-CUT CELL	1965*1303*35	350-450 mm
GROUP 17	CWT108PMB12	PERC MONO BIFACIAL	530W-550W	108 PCS HALF-CUT CELL	1965*1303*35	350-450 mm

GROUP 18	CWT108PMFB12	PERC MONO FULL BLACK	530W-550W	108 PCS HALF-CUT CELL	1965*1303*35	350-450 mm
GROUP 19	CWT120PM12	PERC MONO MULTI BUSBAR	590W-610W	120 PCS HALF-CUT CELL	2172*1303*35	350-450 mm
GROUP 20	CWT120PMB12	PERC MONO BIFACIAL	590W-610W	120 PCS HALF-CUT CELL	2172*1303*35	350-450 mm
GROUP 21	CWT120PMFB12	PERC MONO FULL BLACK	590W-610W	120 PCS HALF-CUT CELL	2172*1303*35	350-450 mm
GROUP 22	CWT132PM12	PERC MONO MULTI BUSBAR	650W-675W	132 PCS HALF-CUT CELL	2384*1303*35	410-510 mm
GROUP 23	CWT132PMB12	PERC MONO BIFACIAL	650W-675W	132 PCS HALF-CUT CELL	2384*1303*35	410-510 mm
GROUP 24	CWT132PMFB12	PERC MONO FULL BLACK	650W-675W	132 PCS HALF-CUT CELL	2384*1303*35	280-380 mm
GROUP 25	CWT108TN10	TOPCON	420W-455W	108 PCS HALF-CUT CELL	1722*1134*30	280-380 mm
GROUP 26	CWT108TNB10	TOPCON BIFACIAL	420W-455W	108 PCS HALF-CUT CELL	1722*1134*30	280-380 mm
GROUP 27	CWT108TNFB10	TOPCON FULL BLACK	435W-450W	108 PCS HALF-CUT CELL	1722*1134*30	300-400 mm
GROUP 28	CWT120TN10	TOPCON	460W-480W	120 PCS HALF-CUT CELL	1909*1134*35	300-400 mm
GROUP 29	CWT120TNFB10	TOPCON FULL BLACK	460W-480W	120 PCS HALF-CUT CELL	1909*1134*35	390-490 mm
GROUP 30	CWT144TN10	TOPCON	590W-620W	144 PCS HALF-CUT CELL	2278*1134*35	390-490 mm
GROUP 31	CWT144TNB10	TOPCON BIFACIAL	590W-620W	144 PCS HALF-CUT CELL	2278*1134*35	390-490 mm
GROUP 32	CWT144TNFB10	TOPCON FULL BLACK	585W-605W	144 PCS HALF-CUT CELL	2278*1134*35	350-450 mm
GROUP 33	CWT108TN12	TOPCON	555W-575W	108 PCS HALF-CUT CELL	1965*1303*35	350-450 mm
GROUP 34	CWT108TNB12	TOPCON BIFACIAL	555W-575W	108 PCS HALF-CUT CELL	1965*1303*35	350-450 mm
GROUP 35	CWT108TNFB12	TOPCON FULL BLACK	555W-575W	108 PCS HALF-CUT CELL	1965*1303*35	350-450 mm
GROUP 36	CWT120TN12	TOPCON	615W-645W	120 PCS HALF-CUT CELL	2172*1303*35	350-450 mm
GROUP 37	CWT120TNB12	TOPCON BIFACIAL	615W-645W	120 PCS HALF-CUT CELL	2172*1303*35	410-510 mm

GROUP 38	CWT120TNFB12	TOPCON FULLBLACK	615W-645W	120 PCS HALF-CUT CELL	2172*1303*35	410-510 mm
GROUP 39	CWT132TN12	TOPCON	695W-730W	132 PCS HALF-CUT CELL	2384*1303*35	410-510 mm
GROUP 40	CWT132TNB12	TOPCON BIFACIAL	715W-755W	132 PCS HALF-CUT CELL	2384*1303*35	410-510 mm
GROUP 41	CWT132TNFB12	TOPCON FULLBLACK	695W-730W	132 PCS HALF-CUT CELL	2384*1303*35	410-510 mm
GROUP 42	CWT108TN12R	TOPCON RECTANGLE	510W-535W	108 PCS HALF-CUT CELL	1965*1134*30	325-425mm
GROUP 43	CWT108TNB12R	TOPCON BIFACIAL RECTANGLE	510W-535W	108 PCS HALF-CUT CELL	1965*1134*30	325-425mm
GROUP 44	CWT108TNFB12R	TOPCON FULLBLACK RECTANGLE	510W-535W	108 PCS HALF-CUT CELL	1965*1134*30	325-425mm
GROUP 45	CWT120TN12R	TOPCON RECTANGLE	570W-595W	120 PCS HALF-CUT CELL	2172*1134*30	350-450mm
GROUP 46	CWT120TNB12R	TOPCON BIFACIAL RECTANGLE	570W-595W	120 PCS HALF-CUT CELL	2172*1134*30	350-450mm
GROUP 47	CWT120TNFB12R	TOPCON FULLBLACK RECTANGLE	570W-595W	120 PCS HALF-CUT CELL	2172*1134*30	350-450mm
GROUP 48	CWT132TN12R	TOPCON RECTANGLE	620W-655W	132 PCS HALF-CUT CELL	2382*1134*30	400-500mm
GROUP 49	CWT132TNB12R	TOPCON BIFACIAL RECTANGLE	620W-655W	132 PCS HALF-CUT CELL	2382*1134*30	400-500mm
GROUP 50	CWT132TNFB12R	TOPCON FULLBLACK RECTANGLE	620W-655W	132 PCS HALF-CUT CELL	2382*1134*30	400-500mm

GROUP 1

CWT60P					
Peak Power (Pmax)	265Wp	270 Wp	275 Wp	280 Wp	285 Wp
Maximum Power Voltage (Vmp)	31,44V (30,49-32,38)	31,81V (30,85-32,76)	32,11V (31,15-33,07)	32,44V (31,47-33,41)	32,69V (31,71-33,67)
Maximum Power Current (Imp)	8,44A (8,19-8,69)	8,5A (8,24-8,75)	8,57A (8,31-8,83)	8,64A (8,38-8,9)	8,72A (8,46-8,98)
Open Circuit Voltage (Voc)	38,64V (37,48-39,8)	38,84V (37,67-40)	39,2V (38,02-40,38)	39,50V (38,31-40,68)	39,74V (38,55-40,93)
Short Circuit Current (Isc)	9,04A (8,77-9,31)	9,10V (8,83-9,37)	9,17A (8,89-9,44)	9,22A (8,94-9,5)	9,30A (9,02-9,58)

GROUP 2

CWT72P					
Peak Power (Pmax)	320Wp	325 Wp	330 Wp	335 Wp	340 Wp
Maximum Power Voltage (Vmp)	37,82V (36,38-38,95)	38,11V (36,97-39,25)	38,45V (37,3-39,6)	38,83V (37,66-40)	39,18V (38-40,35)
Maximum Power Current (Imp)	8,47A (8,21-8,68)	8,53A (8,27-8,78)	8,59A (8,33-8,85)	8,63A (8,37-8,89)	8,68A (8,42-8,94)
Open Circuit Voltage (Voc)	46,50V (45,1-47,89)	46,75V (44,85-48,15)	47,01V (45,6-48,42)	47,26V (45,84-48,68)	47,63V (46,2-49,06)
Short Circuit Current (Isc)	9,06A (8,79-9,33)	9,12A (8,85-9,39)	9,17A (8,89-9,44)	9,21A (8,93-9,49)	9,24A (8,96-9,52)

GROUP 3

CWT60PM						
Peak Power (Pmax)	310 Wp	315 Wp	320 Wp	325 Wp	330 Wp	335 Wp
Maximum Power Voltage (Vmp)	33,04V (32,05-34,03)	33,55V (32,54-34,56)	33,65V (32,64-34,66)	33,92V (32,9-34,94)	34,11V (33,09-35,13)	34,4V (33,37-35,43)
Maximum Power Current (Imp)	9,40A	9,41A	9,52A	9,58A	9,68A	9,75A
Open Circuit Voltage (Voc)	40,15V	40,73V	40,84V	41,14V	41,34V	41,56V
Short Circuit Current (Isc)	10,03A	10,05A	10,16A	10,23A	10,33A	10,38A

GROUP 4

CWT72PM						
Peak Power (Pmax)	375 Wp	380 Wp	385 Wp	390 Wp	395 Wp	400 Wp
Maximum Power Voltage (Vmp)	40,14V	40,52V	40,7V	40,88V	41,07V	41,1V
Maximum Power Current (Imp)	9,35A	9,39A	9,47A	9,55A	9,62A	9,75A
Open Circuit Voltage (Voc)	48,67V	48,91V	49,12V	49,32V	49,54V	49,83V
Short Circuit Current (Isc)	9,94A	9,97A	10,05A	10,13A	10,24A	10,38A

GROUP 5

CWT120PM-HC-MULTIBUSBAR					
Peak Power (Pmax)	360 Wp	365 Wp	370 Wp	375 Wp	380 Wp
Maximum Power Voltage (Vmp)	33,90V	34,10V	34,30V	34,50V	34,70V
Maximum Power Current (Imp)	10,62A	10,71A	10,79A	10,87A	10,94A
Open Circuit Voltage (Voc)	40,50V	40,70V	40,90V	41,10V	41,30V
Short Circuit Current (Isc)	11,35A	11,42A	11,49A	11,57A	11,64A

GROUP 6

CWT144PM-HC- MULTIBUSBAR					
Peak Power (Pmax)	435 Wp	440 Wp	445 Wp	450 Wp	455 Wp
Maximum Power Voltage (Vmp)	40,8V	41,0V	41,2V	41,4V	41,6V
Maximum Power Current (Imp)	10,67A	10,74A	10,81A	10,87A	10,94A
Open Circuit Voltage (Voc)	48,60V	48,80V	49,00V	49,20V	49,40V
Short Circuit Current (Isc)	11,40A	11,47A	11,54A	11,61A	11,67A

GROUP 7

CWT108PM10- MULTIBUSBAR				
Peak Power (Pmax)	395 Wp	400 Wp	405 Wp	410 Wp
Maximum Power Voltage (Vmp)	30,90V	31,10V	31,30V	31,50V
Maximum Power Current (Imp)	12,79A	12,86A	12,94A	13,02A
Open Circuit Voltage (Voc)	36,90V	37,10V	37,40V	37,60V
Short Circuit Current (Isc)	13,62A	13,70A	13,77A	13,85A

GROUP 8

CWT108PMB10- PERC MONO BIFACIAL				
Peak Power (Pmax)	395 Wp	400 Wp	405 Wp	410 Wp
Maximum Power Voltage (Vmp)	30,90V	31,10V	31,30V	31,50V
Maximum Power Current (Imp)	12,79A	12,86A	12,94A	13,02A
Open Circuit Voltage (Voc)	36,90V	37,10V	37,40V	37,60V
Short Circuit Current (Isc)	13,62A	13,70A	13,77A	13,85A

GROUP 9

CWT108PMFB10- PERC MONO FULLBLACK				
Peak Power (Pmax)	395 Wp	400 Wp	405 Wp	410 Wp
Maximum Power Voltage (Vmp)	30,90V	31,10V	31,30V	31,50V
Maximum Power Current (Imp)	12,79A	12,86A	12,94A	13,02A
Open Circuit Voltage (Voc)	36,90V	37,10V	37,40V	37,60V
Short Circuit Current (Isc)	13,62A	13,70A	13,77A	13,85A

GROUP 10

CWT144PM10- PERC MONO MULTIBUSBAR					
Peak Power (Pmax)	530 Wp	535 Wp	540 Wp	545 Wp	550 Wp
Maximum Power Voltage (Vmp)	41,60V	41,80V	42,00V	42,20V	42,40V
Maximum Power Current (Imp)	12,75A	12,80A	12,86A	12,92A	12,98A
Open Circuit Voltage (Voc)	49,40V	49,60V	49,80V	50,00V	50,20V
Short Circuit Current (Isc)	13,58A	13,63A	13,70A	13,76A	13,82A

GROUP 11

CWT144PMB10- PERC MONO BIFACIAL					
Peak Power (Pmax)	530 Wp	535 Wp	540 Wp	545 Wp	550 Wp
Maximum Power Voltage (Vmp)	41,60V	41,80V	42,00V	42,20V	42,40V
Maximum Power Current (Imp)	12,75A	12,80A	12,86A	12,92A	12,98A
Open Circuit Voltage (Voc)	49,40V	49,60V	49,80V	50,00V	50,20V
Short Circuit Current (Isc)	13,58A	13,63A	13,70A	13,76A	13,82A

GROUP 12

CWT144PMFB10- PERC MONO FULLBLACK					
Peak Power (Pmax)	530 Wp	535 Wp	540 Wp	545 Wp	550 Wp
Maximum Power Voltage (Vmp)	41,6V	41,80V	42,00V	42,20V	42,40V
Maximum Power Current (Imp)	12,75A	12,80A	12,86A	12,92A	12,98A
Open Circuit Voltage (Voc)	49,40V	49,60V	49,80V	50,00V	50,20V
Short Circuit Current (Isc)	13,58A	13,63A	13,70A	13,76A	13,82A

GROUP 13

CWT156PM10- PERC MONO MULTIBUSBAR					
Peak Power (Pmax)	575 Wp	580 Wp	585 Wp	590 Wp	595 Wp
Maximum Power Voltage (Vmp)	45,00V	45,20V	45,40V	45,60V	45,80V
Maximum Power Current (Imp)	12,78A	12,84A	12,89A	12,94A	12,99A
Open Circuit Voltage (Voc)	53,50V	53,70V	53,90V	54,10V	54,30V
Short Circuit Current (Isc)	13,61A	13,67A	13,73A	13,78A	13,84A

GROUP 14

CWT156PMB10- PERC MONO BIFACIAL					
Peak Power (Pmax)	575 Wp	580 Wp	585 Wp	590 Wp	595 Wp
Maximum Power Voltage (Vmp)	45,00V	45,2V	45,40V	45,60V	45,80V
Maximum Power Current (Imp)	12,78A	12,84A	12,89A	12,94A	12,99A
Open Circuit Voltage (Voc)	53,50V	53,70V	53,90V	54,10V	54,30V
Short Circuit Current (Isc)	13,61A	13,67A	13,73A	13,78A	13,84A

GROUP 15

CWT156PMFB10- PERC MONO FULLBLACK					
Peak Power (Pmax)	575 Wp	580 Wp	585 Wp	590 Wp	595 Wp
Maximum Power Voltage (Vmp)	45,00V	45,20V	45,40V	45,60V	45,80V
Maximum Power Current (Imp)	12,78A	12,84A	12,89A	12,94A	12,99A
Open Circuit Voltage (Voc)	53,50V	53,70V	53,90V	54,10V	54,30V
Short Circuit Current (Isc)	13,61A	13,67A	13,73A	13,78A	13,84A

GROUP 16

CWT108PM12- PERC MONO MULTIBUSBAR					
Peak Power (Pmax)	530 Wp	535 Wp	540 Wp	545 Wp	550 Wp
Maximum Power Voltage (Vmp)	30,70V	30,90V	31,10V	31,30V	31,50V
Maximum Power Current (Imp)	17,27A	17,31A	17,36A	17,42A	17,46A
Open Circuit Voltage (Voc)	37,00V	37,20V	37,50V	37,70V	37,90V
Short Circuit Current (Isc)	18,28A	18,33A	18,38A	18,45A	18,49A

GROUP 17

CWT108PMB12- PERC MONO BIFACIAL					
Peak Power (Pmax)	530 Wp	535 Wp	540 Wp	545 Wp	550 Wp
Maximum Power Voltage (Vmp)	30,70V	30,90V	31,10V	31,30V	31,50V
Maximum Power Current (Imp)	17,27A	17,31A	17,36A	17,42A	17,46A
Open Circuit Voltage (Voc)	37,00V	37,20V	37,50V	37,70V	37,90V
Short Circuit Current (Isc)	18,28A	18,33A	18,38A	18,45A	18,49A

GROUP 18

CWT108PMFB12- PERC MONO FULLBLACK					
Peak Power (Pmax)	530 Wp	535 Wp	540 Wp	545 Wp	550 Wp
Maximum Power Voltage (Vmp)	30,70V	30,90V	31,10V	31,30V	31,50V
Maximum Power Current (Imp)	17,27A	17,31A	17,36A	17,42A	17,46A
Open Circuit Voltage (Voc)	37,00V	37,20V	37,50V	37,70V	37,90V
Short Circuit Current (Isc)	18,28A	18,33A	18,38A	18,45A	18,49A

GROUP 19

CWT120PM12- PERC MONO MULTIBUSBAR					
Peak Power (Pmax)	590 Wp	595 Wp	600 Wp	605 Wp	610 Wp
Maximum Power Voltage (Vmp)	34,10V	34,20V	34,30V	34,50V	34,70V
Maximum Power Current (Imp)	17,30A	17,40A	17,50A	17,54A	17,58A
Open Circuit Voltage (Voc)	41,10V	41,30V	41,50V	41,70V	41,90V
Short Circuit Current (Isc)	18,33A	18,43A	18,53A	18,68A	18,62A

GROUP 20

CWT120PMB12- PERC MONO BIFACIAL					
Peak Power (Pmax)	590 Wp	595 Wp	600 Wp	605 Wp	610 Wp
Maximum Power Voltage (Vmp)	34,10V	34,20V	34,30V	34,50V	34,70V
Maximum Power Current (Imp)	17,30A	17,40A	17,50A	17,54A	17,58A
Open Circuit Voltage (Voc)	41,10V	41,30V	41,50V	41,70V	41,90V
Short Circuit Current (Isc)	18,33A	18,43A	18,53A	18,68A	18,62A

GROUP 21

CWT120PMFB12- PERC MONO FULLBLACK					
Peak Power (Pmax)	590 Wp	595 Wp	600 Wp	605 Wp	610 Wp
Maximum Power Voltage (Vmp)	34,10V	34,20V	34,30V	34,50V	34,70V
Maximum Power Current (Imp)	17,30A	17,40A	17,50A	17,54A	17,58A
Open Circuit Voltage (Voc)	41,10V	41,30V	41,50V	41,70V	41,90V
Short Circuit Current (Isc)	18,33A	18,43A	18,53A	18,68A	18,62A

GROUP 22

CWT132PM12- PERC MONO MULTIBUSBAR						
Peak Power (Pmax)	650 Wp	655 Wp	660 Wp	665 Wp	670 Wp	675 Wp
Maximum Power Voltage (Vmp)	37,50V	37,70V	37,90V	38,10V	38,30V	38,50V
Maximum Power Current (Imp)	17,34A	17,38A	17,42A	17,46A	17,50A	17,54A
Open Circuit Voltage (Voc)	45,20V	45,40V	45,60V	45,80V	46,00V	46,20V
Short Circuit Current (Isc)	18,35A	18,39A	18,44A	18,48A	18,51A	18,56A

GROUP 23

CWT132PMB12- PERC MONO BIFACIAL						
Peak Power (Pmax)	650 Wp	655 Wp	660 Wp	665 Wp	670 Wp	675 Wp
Maximum Power Voltage (Vmp)	37,50V	37,70V	37,90V	38,10V	38,30V	38,50V
Maximum Power Current (Imp)	17,34A	17,38A	17,42A	17,46A	17,50A	17,54A
Open Circuit Voltage (Voc)	45,20V	45,40V	45,60V	45,80V	46,00V	46,20V
Short Circuit Current (Isc)	18,35A	18,39A	18,44A	18,48A	18,51A	18,56A

GROUP 24

CWT132PMFB12- PERC MONO FULLBLACK						
Peak Power (Pmax)	650 Wp	655 Wp	660 Wp	665 Wp	670 Wp	675 Wp
Maximum Power Voltage (Vmp)	37,50V	37,70V	37,90V	38,10V	38,30V	38,50V
Maximum Power Current (Imp)	17,34A	17,38A	17,42A	17,46A	17,50A	17,54A
Open Circuit Voltage (Voc)	45,20V	45,40V	45,60V	45,80V	46,00V	46,20V
Short Circuit Current (Isc)	18,35A	18,39A	18,44A	18,48A	18,51A	18,56A

GROUP 25

CWT108TN10-TOPCON								
Peak Power (Pmax)	420 Wp	425 Wp	430 Wp	435 Wp	440 Wp	445 Wp	450 Wp	455 Wp
Maximum Power Voltage (Vmp)	31.94V	32.14V	32.34V	32.54V	32.74V	32.94V	33.14V	33.34V
Maximum Power Current (Imp)	13.15A	13.23A	13.30A	13.37A	13.44A	13.51A	13.58A	13.65A
Open Circuit Voltage (Voc)	38.11V	38.31V	38.51V	38.71V	38.91V	39.11V	39.31V	39.51V
Short Circuit Current (Isc)	13.95A	14.03A	14.10A	14.17A	14.24A	14.31A	14.38A	14.45A

GROUP 26

CWT108TNB10-TOPCON BIFACIAL								
Peak Power (Pmax)	420 Wp	425 Wp	430 Wp	435 Wp	440 Wp	445 Wp	450 Wp	455 Wp
Maximum Power Voltage (Vmp)	31.94V	32.14V	32.34V	32.54V	32.74V	32.94V	33.14V	33.34V
Maximum Power Current (Imp)	13.15A	13.23A	13.30A	13.37A	13.44A	13.51A	13.58A	13.65A
Open Circuit Voltage (Voc)	38.11V	38.31V	38.51V	38.71V	38.91V	39.11V	39.31V	39.51V
Short Circuit Current (Isc)	13.95A	14.03A	14.10A	14.17A	14.24A	14.31A	14.38A	14.45A

GROUP 27

CWT108TNFB10- TOPCON FULLBLACK				
Peak Power (Pmax)	435 Wp	440 Wp	445 Wp	450 Wp
Maximum Power Voltage (Vmp)	32,54V	32,74V	32,94V	33,14V
Maximum Power Current (Imp)	13,37A	13,44A	13,51A	13,58A
Open Circuit Voltage (Voc)	38,51V	38,71V	38,91V	39,11V
Short Circuit Current (Isc)	14,17A	14,24A	14,30A	14,38A

GROUP 28

CWT120TN10-TOPCON					
Peak Power (Pmax)	460 Wp	465 Wp	470 Wp	475 Wp	480 Wp
Maximum Power Voltage (Vmp)	35,26V	35,46V	35,66 V	35,86 V	36,06 V
Maximum Power Current (Imp)	13,05A	13,12A	13,19A	13,25A	13,32A
Open Circuit Voltage (Voc)	41,90V	42,10V	42,30V	42,50V	42,70V
Short Circuit Current (Isc)	13,86A	13,93A	14,00A	14,08A	14,14A

GROUP 29

CWT120TNFB10-TOPCON FULLBLACK					
Peak Power (Pmax)	460 Wp	465 Wp	470 Wp	475 Wp	480 Wp
Maximum Power Voltage (Vmp)	35,26V	35,46V	35,66 V	35,86 V	36,06 V
Maximum Power Current (Imp)	13,05A	13,12A	13,19A	13,25A	13,32A
Open Circuit Voltage (Voc)	41,90V	42,10V	42,30V	42,50V	42,70V
Short Circuit Current (Isc)	13,86A	13,93A	14,00A	14,08A	14,14A

GROUP 30

CWT144TN10-TOPCON							
Peak Power (Pmax)	590 Wp	595 Wp	600 Wp	605 Wp	610 Wp	615 Wp	620 Wp
Maximum Power Voltage (Vmp)	43.35V	43.55V	43.75V	43.95V	44.15V	44.35V	44.55V
Maximum Power Current (Imp)	13.62A	13.67A	13.72A	13.77A	13.82A	13.87A	13.92A
Open Circuit Voltage (Voc)	51.98V	52.18V	52.38V	52.58V	52.78V	52.98V	53.18V
Short Circuit Current (Isc)	14.30A	14.36A	14.42A	14.48A	14.54A	14.60A	14.66A

GROUP 31

CWT144TNB10-TOPCON BIFACIAL							
Peak Power (Pmax)	590 Wp	595 Wp	600 Wp	605 Wp	610 Wp	615 Wp	620 Wp
Maximum Power Voltage (Vmp)	43.35V	43.55V	43.75V	43.95V	44.15V	44.35V	44.55V
Maximum Power Current (Imp)	13.62A	13.67A	13.72A	13.77A	13.82A	13.87A	13.92A
Open Circuit Voltage (Voc)	51.98V	52.18V	52.38V	52.58V	52.78V	52.98V	53.18V
Short Circuit Current (Isc)	14.30A	14.36A	14.42A	14.48A	14.54A	14.60A	14.66A

GROUP 32

CWT144TNFB10-TOPCON FULLBLACK							
Peak Power (Pmax)	590 Wp	595 Wp	600 Wp	605 Wp	610 Wp	615 Wp	620 Wp
Maximum Power Voltage (Vmp)	43.35V	43.55V	43.75V	43.95V	44.15V	44.35V	44.55V
Maximum Power Current (Imp)	13.62A	13.67A	13.72A	13.77A	13.82A	13.87A	13.92A
Open Circuit Voltage (Voc)	51.98V	52.18V	52.38V	52.58V	52.78V	52.98V	53.18V
Short Circuit Current (Isc)	14.30A	14.36A	14.42A	14.48A	14.54A	14.60A	14.66A

GROUP 33

CWT108TN12- TOPCON					
Peak Power (Pmax)	555Wp	560Wp	565Wp	570Wp	575Wp
Maximum Power Voltage (Vmp)	32.40V	32.60V	32.80V	33.00V	33.20V
Maximum Power Current (Imp)	17.13A	17.18A	17.23A	17.28A	17.32A
Open Circuit Voltage (Voc)	37.60V	37.80V	38.00V	38.20V	38.40V
Short Circuit Current (Isc)	18.22A	18.27A	18.33A	18.38A	18.42A

GROUP 34

CWT108TNB12- TOPCON BIFACIAL					
Peak Power (Pmax)	555Wp	560Wp	565Wp	570Wp	575Wp
Maximum Power Voltage (Vmp)	32.40V	32.60V	32.80V	33.00V	33.20V
Maximum Power Current (Imp)	17.13A	17.18A	17.23A	17.28A	17.32A
Open Circuit Voltage (Voc)	37.60V	37.80V	38.00V	38.20V	38.40V
Short Circuit Current (Isc)	18.22A	18.27A	18.33A	18.38A	18.42A

GROUP 35

CWT108TNFB12- TOPCON FULLBLACK					
Peak Power (Pmax)	555Wp	560Wp	565Wp	570Wp	575Wp
Maximum Power Voltage (Vmp)	32.40V	32.60V	32.80V	33.00V	33.20V
Maximum Power Current (Imp)	17.13A	17.18A	17.23A	17.28A	17.32A
Open Circuit Voltage (Voc)	37.60V	37.80V	38.00V	38.20V	38.40V
Short Circuit Current (Isc)	18.22A	18.27A	18.33A	18.38A	18.42A

GROUP 36

CWT120TN12-TOPCON							
Peak Power (Pmax)	615 Wp	620 Wp	625 Wp	630 Wp	635 Wp	640 Wp	645 Wp
Maximum Power Voltage (Vmp)	35,56V	35,76V	35,96V	36,16V	36,36V	36,56V	36,60V
Maximum Power Current (Imp)	17,30A	17,34A	17,39A	17,43A	17,45A	17,51A	17,55A
Open Circuit Voltage (Voc)	42,78V	42,98V	43,18V	43,38V	43,58V	43,78V	43,98V
Short Circuit Current (Isc)	18,24A	18,30A	18,35A	18,40A	18,46A	18,52A	18,57A

GROUP 37

CWT120TNB12-TOPCON BIFACIAL							
Peak Power (Pmax)	615 Wp	620 Wp	625 Wp	630 Wp	635 Wp	640 Wp	645 Wp
Maximum Power Voltage (Vmp)	35,56V	35,76V	35,96V	36,16V	36,36V	36,56V	36,60V
Maximum Power Current (Imp)	17,30A	17,34A	17,39A	17,43A	17,45A	17,51A	17,55A
Open Circuit Voltage (Voc)	42,78V	42,98V	43,18V	43,38V	43,58V	43,78V	43,98V
Short Circuit Current (Isc)	18,24A	18,30A	18,35A	18,40A	18,46A	18,52A	18,57A

GROUP 38

CWT120TNFB12-TOPCON FULLBLACK							
Peak Power (Pmax)	615 Wp	620 Wp	625 Wp	630 Wp	635 Wp	640 Wp	645 Wp
Maximum Power Voltage (Vmp)	35,56V	35,76V	35,96V	36,16V	36,36V	36,56V	36,60V
Maximum Power Current (Imp)	17,30A	17,34A	17,39A	17,43A	17,45A	17,51A	17,55A
Open Circuit Voltage (Voc)	42,78V	42,98V	43,18V	43,38V	43,58V	43,78V	43,98V
Short Circuit Current (Isc)	18,24A	18,30A	18,35A	18,40A	18,46A	18,52A	18,57A

GROUP 39

CWT132TN12- TOPCON								
Peak Power (Pmax)	695 Wp	700 Wp	705 Wp	710 Wp	715 Wp	720 Wp	725 Wp	730 Wp
Maximum Power Voltage (Vmp)	40,10V	40,30V	40,50V	40,70V	40,90V	41,10V	41,30V	41,50V
Maximum Power Current (Imp)	17,33A	17,37A	17,41A	17,45A	17,49A	17,52A	17,56A	17,60A
Open Circuit Voltage (Voc)	46,70V	46,90V	47,10V	47,30V	47,50V	47,70V	47,90V	48,10V
Short Circuit Current (Isc)	18,42A	18,47A	18,52A	18,57A	18,62A	18,67A	18,72A	18,76A

GROUP 40

CWT132TNB12- TOPCON BIFACIAL									
Peak Power (Pmax)	715 Wp	720 Wp	725 Wp	730 Wp	735 Wp	740 Wp	745 Wp	750 Wp	755 Wp
Maximum Power Voltage (Vmp)	40.30V	40.50V	40.70V	40.90V	41.10V	41.30V	41.50V	41.70V	41.90V
Maximum Power Current (Imp)	17.75A	17.78A	17.82A	17.85A	17.89A	17.92A	17.96A	17.99A	18.02A
Open Circuit Voltage (Voc)	48.40V	48.60V	48.80V	49.00V	49.20V	49.40V	49.60V	49.80V	50.00V
Short Circuit Current (Isc)	18.62A	18.67A	18.72A	18.76A	18.80A	18.85A	18.89A	18.95A	18.99A

GROUP 41

CWT132TNFB12- TOPCON FULLBLACK									
Peak Power (Pmax)	715 Wp	720 Wp	725 Wp	730 Wp	735 Wp	740 Wp	745 Wp	750 Wp	755 Wp
Maximum Power Voltage (Vmp)	40.30V	40.50V	40.70V	40.90V	41.10V	41.30V	41.50V	41.70V	41.90V
Maximum Power Current (Imp)	17.75A	17.78A	17.82A	17.85A	17.89A	17.92A	17.96A	17.99A	18.02A
Open Circuit Voltage (Voc)	48.40V	48.60V	48.80V	49.00V	49.20V	49.40V	49.60V	49.80V	50.00V
Short Circuit Current (Isc)	18.62A	18.67A	18.72A	18.76A	18.80A	18.85A	18.89A	18.95A	18.99A

GROUP 42

CWT108TN12R- TOPCON RECTANGLE						
Peak Power (Pmax)	510 Wp	515 Wp	520 Wp	525 Wp	530 Wp	535 Wp
Maximum Power Voltage (Vmp)	33,75V	33,95V	34,15V	34,35V	34,55V	34,75V
Maximum Power Current (Imp)	15,12A	15,17A	15,23A	15,29A	15,35A	15,40A
Open Circuit Voltage (Voc)	39,95V	40,15V	40,35V	40,55V	40,75V	40,95V
Short Circuit Current (Isc)	15,95A	16,01A	16,07A	16,13A	16,13A	16,25A

GROUP 43

CWT108TNB12R- TOPCON BIFACIAL RECTANGLE						
Peak Power (Pmax)	510 Wp	515 Wp	520 Wp	525 Wp	530 Wp	535 Wp
Maximum Power Voltage (Vmp)	33,75V	33,95V	34,15V	34,35V	34,55V	34,75V
Maximum Power Current (Imp)	15,12A	15,17A	15,23A	15,29A	15,35A	15,40A
Open Circuit Voltage (Voc)	39,95V	40,15V	40,35V	40,55V	40,75V	40,95V
Short Circuit Current (Isc)	15,95A	16,01A	16,07A	16,13A	16,13A	16,25A

GROUP 44

CWT108TNFB12R- TOPCON FULLBLACK RECTANGLE						
Peak Power (Pmax)	510 Wp	515 Wp	520 Wp	525 Wp	530 Wp	535 Wp
Maximum Power Voltage (Vmp)	33,75V	33,95V	34,15V	34,35V	34,55V	34,75V
Maximum Power Current (Imp)	15,12A	15,17A	15,23A	15,29A	15,35A	15,40A
Open Circuit Voltage (Voc)	39,95V	40,15V	40,35V	40,55V	40,75V	40,95V
Short Circuit Current (Isc)	15,95A	16,01A	16,07A	16,13A	16,13A	16,25A

GROUP 45

CWT120TN12R- TOPCON RECTANGLE						
Peak Power (Pmax)	570 Wp	575 Wp	580 Wp	585 Wp	590 Wp	595 Wp
Maximum Power Voltage (Vmp)	37,61V	37,81V	38,01V	38,21V	38,41V	38,61V
Maximum Power Current (Imp)	15,16A	15,21A	15,26A	15,32A	15,37A	15,42A
Open Circuit Voltage (Voc)	44,50V	44,70V	44,90V	45,10V	45,30V	45,50V
Short Circuit Current (Isc)	16,06A	16,12A	16,18A	16,24A	16,30A	16,36A

GROUP 46

CWT120TNB12R- TOPCON BIFACIAL RECTANGLE						
Peak Power (Pmax)	570 Wp	575 Wp	580 Wp	585 Wp	590 Wp	595 Wp
Maximum Power Voltage (Vmp)	37,61V	37,81V	38,01V	38,21V	38,41V	38,61V
Maximum Power Current (Imp)	15,16A	15,21A	15,26A	15,32A	15,37A	15,42A
Open Circuit Voltage (Voc)	44,50V	44,70V	44,90V	45,10V	45,30V	45,50V
Short Circuit Current (Isc)	16,06A	16,12A	16,18A	16,24A	16,30A	16,36A

GROUP 47

CWT120TNFB12R- TOPCON FULLBLACK RECTANGLE						
Peak Power (Pmax)	570 Wp	575 Wp	580 Wp	585 Wp	590 Wp	595 Wp
Maximum Power Voltage (Vmp)	37,61V	37,81V	38,01V	38,21V	38,41V	38,61V
Maximum Power Current (Imp)	15,16A	15,21A	15,26A	15,32A	15,37A	15,42A
Open Circuit Voltage (Voc)	44,50V	44,70V	44,90V	45,10V	45,30V	45,50V
Short Circuit Current (Isc)	16,06A	16,12A	16,18A	16,24A	16,30A	16,36A

GROUP 48

CWT132TN12R- TOPCON RECTANGLE								
Peak Power (Pmax)	620 Wp	625 Wp	630 Wp	635 Wp	640 Wp	645 Wp	650 Wp	655 Wp
Maximum Power Voltage (Vmp)	41.02V	41.22V	41.42V	41.62V	41.82V	42.02V	42.22V	42.42V
Maximum Power Current (Imp)	15.12A	15.17A	15.22A	15.26A	15.31A	15.35A	15.40A	15.45A
Open Circuit Voltage (Voc)	48.99V	49.19V	49.39V	49.59V	49.79V	49.99V	50.19V	50.39V
Short Circuit Current (Isc)	16.02A	16.08A	16.14A	16.20A	16.26A	16.32A	16.38A	16.44A

GROUP 49

CWT132TNB12R- TOPCON RECTANGLE								
Peak Power (Pmax)	620 Wp	625 Wp	630 Wp	635 Wp	640 Wp	645 Wp	650 Wp	655 Wp
Maximum Power Voltage (Vmp)	41.02V	41.22V	41.42V	41.62V	41.82V	42.02V	42.22V	42.42V
Maximum Power Current (Imp)	15.12A	15.17A	15.22A	15.26A	15.31A	15.35A	15.40A	15.45A
Open Circuit Voltage (Voc)	48.99V	49.19V	49.39V	49.59V	49.79V	49.99V	50.19V	50.39V
Short Circuit Current (Isc)	16.02A	16.08A	16.14A	16.20A	16.26A	16.32A	16.38A	16.44A

GROUP 50

CWT132TNFB12R- TOPCON FULLBLACK RECTANGLE								
Peak Power (Pmax)	620 Wp	625 Wp	630 Wp	635 Wp	640 Wp	645 Wp	650 Wp	655 Wp
Maximum Power Voltage (Vmp)	41.02V	41.22V	41.42V	41.62V	41.82V	42.02V	42.22V	42.42V
Maximum Power Current (Imp)	15.12A	15.17A	15.22A	15.26A	15.31A	15.35A	15.40A	15.45A
Open Circuit Voltage (Voc)	48.99V	49.19V	49.39V	49.59V	49.79V	49.99V	50.19V	50.39V
Short Circuit Current (Isc)	16.02A	16.08A	16.14A	16.20A	16.26A	16.32A	16.38A	16.44A

All values measured at STC; 1000W/m², 25°C, 1.5AM