

USER MANUAL

12.8V / 25.6V Lithium Battery

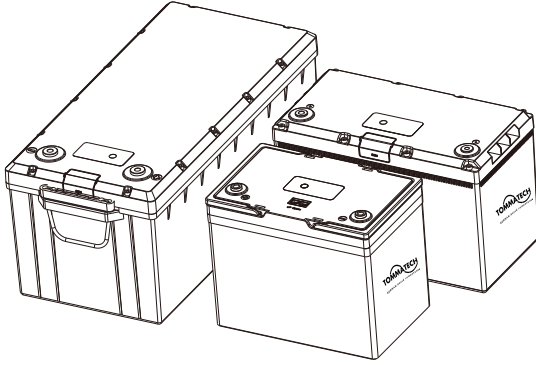

End User Documentation

Rev 2.0

Oct -01-2024

DOCUMENT NOTICE: The information contained in this manual is the property of TommaTech GmbH ("TOMMATECH") and is subject to change without notice. TommaTech reserves the right to make changes in the design of its products or components as progress in engineering and manufacturing may warrant. It is the customer's responsibility to satisfy itself as to whether the information contained herein is adequate and Sufficient for a user's particular use. It is the further responsibility of each user to ensure that all applications of TOMMATECH's products are appropriate and safe based on conditions anticipated or encountered during use. This document does not create any additional obligation for TOMMATECH and does not constitute additional warranties and representations.

12.8V / 25.6V LITHIUM BATTERY

12.8V/25.6V Lithium battery, is intended as a replacement for the common 12V lead acid battery and traditional case lithium battery. Lithium battery adopt removable enclosure and modular design which support to assembly in local.

The lithium battery adopt Iron Phosphate (LiFePO₄) cells and unique BMS to provide safety, high current and prominent long life performance, with 20 times longer cyclic life than SLA battery to save cost and energy, up to 70% lighter than SLA battery to save logistic cost. Diverse accessories which include Bluetooth modules, heater components, LED display units and communication ports.

This document is intended for use by anyone required to install and operate new generation lithium batteries. Be sure review this manual carefully to identify any potential safety risks before proceeding.

The owner must be familiar with all the features of this product before proceeding.

Failure to install or use this product as instructed can result in damage to the product that may not be covered under the limited warranty.

This manual suitable for below models:



Figure 1. New Generator Lithium Battery

BTR-MRN1-12.8V-100AH-S

BTR-MRN1-12.8V-200AH

BTR-MRN3-12.8V-200AH

BTR-MRN1-25.6V-100AH

BTR-MRN3-25.6V-100AH

BTR-MRN1-25.6V-200AH

**WARNING: Explosion, Electrocution, Or Fire Hazard**

- A battery can present a risk of electric shock, burns from short circuit current, fire, or explosion.
- Observe proper precautions.
- Ensure the cables are properly sized.
- Ensure clearance requirements are strictly enforced around the batteries.
- Ensure the area around the lithium battery is well ventilated and clean of debris.
- Always use insulated tools. Avoid dropping tools onto batteries or other electrical parts.
- Never charge a frozen lithium battery unless optional heater parts inside.
- If a lithium battery must be removed, always remove the grounded terminal from the battery first. Make sure all devices are disconnected.

**IMPORTANT**

- When installing batteries, leave adequate clearance between lithium batteries.
- When replacing batteries, use the same number and type of lithium batteries.
- Avoid any fall or collision during the installation process.
- Do not remove the lithium battery components. The maintenance of the lithium battery should be carried out by a professional engineer.
- Do not expose the lithium battery to heat in excess of 58°C during operation, 60°C in storage.
- Do not incinerate or expose to open flames.
- Do not connect over 4 sets 12.8V or 2 sets 25.6V lithium batteries in series. Wrong operation will damage the BMS.
- Before series connection, it's better to make sure fully charge or discharge single lithium battery. The different SOC between lithium battery may cause the whole group to fail to charge and discharge normally reduce the usable capacity of the battery group.
- Before parallel connection, it's better to make sure the voltage difference less than 0.1V to avoid large current impact.
- Do not connect in series at the same time connect in parallel.
- Recharge in time after fully charge to avoid BMS can't working to cause lithium battery scrapped.

Storage

The 12.8V/25.6V lithium battery can be stored in an environment with temperatures between -20°C and $+55^{\circ}\text{C}$ and between 10% and 90% relative humidity, non condensing.

For long storage periods at 25°C , charge the lithium battery every half years. For temperatures above 40°C , charge the battery quarterly.

Do not store the Li-ion battery at temperatures above 60°C .

The battery SOC is 50% during delivery, it needs to recharge after 9~10 months during storage

Do not store a fully discharged battery for long time which may cause BMS can't working and battery scrapped.

Relationship Between Charge Limits and Temperature

12.8V/25.6V Lithium battery can be stored in non-condensing environments at temperatures between -20°C and $+55^{\circ}\text{C}$ and relative humidity levels between 10% and 90%.

For long-term storage at 25°C , charge the battery every 6 months.

At temperatures above 40°C , charge the battery every 3 months.

Do not store the lithium battery at temperatures above 60°C .

The battery is delivered at a 50% SOC level; it must be recharged after 9 to 10 months of storage.

Do not store a fully discharged battery for long periods; this may cause the BMS to malfunction and render the battery unusable.

Temperature ($^{\circ}\text{C}$)	Max. Charge Current
-20	Prohibit charging
-10	Prohibit charging
0	0.1C
10	Recommended charge current
20	Max. continuous charge current
35	Recommended charge current
45	0.2C
>55	Prohibit charging

Table 1 Charge Rate by Temperature

Series Strings

The lithium batteries can be combined together in series strings to achieve higher operating voltages by connecting the positive terminal of one battery to the negative terminal of the next lithium battery.

The maximum number of 12.8V lithium battery that you can connect in a series is four (4). The maximum number of 25.6V lithium battery that you can connect in a series is two (2). Below figure 2 illustrates four 12.8V lithium battery connected in series, for a 4S1P configuration.

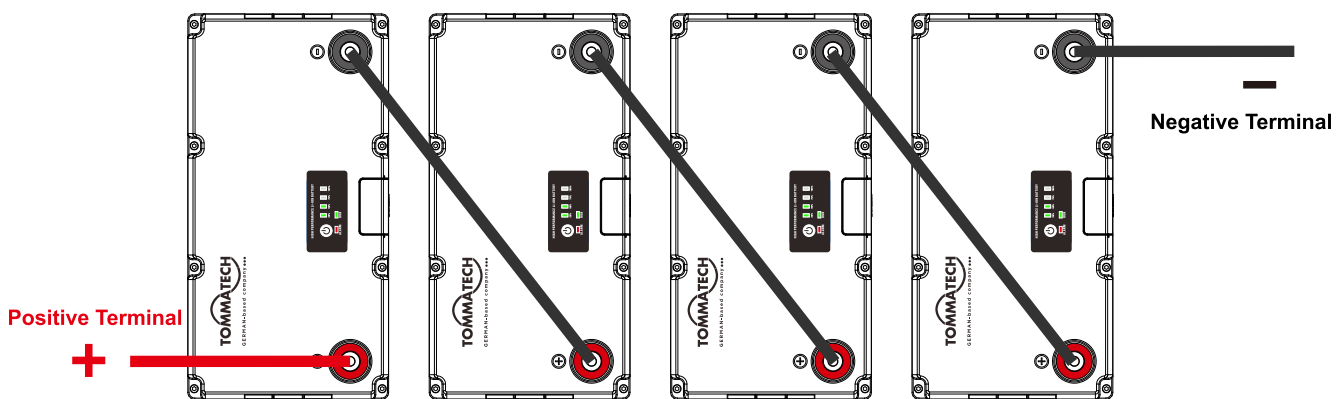

Figure 2. Connecting Batteries in Series (4S1P Configuration)

Two batteries in series: $2 \times 12.8V = 25.6V$ (nominal) for 24V applications

Three batteries in series: $3 \times 12.8V = 38.4V$ (nominal) for 36V applications

Four batteries in series: $4 \times 12.8V = 51.2V$ (nominal) for 48V applications



CAUTION

- Failure to follow the following safety instructions may result in personal injuries or damage to the equipment!
- Do not connect more than four batteries in series. Connecting more than four batteries in series exceeds the voltage limit of the BMS.
- Do not short circuit the lithium battery.
- Do not connect different batches, different types, old and new batteries in series.
- Ensure the batteries consistency before connecting in series.
- For series connection, if one of batteries is charged fully (100% SOC), the other batteries will not be charged anymore, this may cause some batteries SOC won't show 100%, it don't effect the performance of battery.

Parallel Strings

You can combine lithium battery together in parallel strings to achieve higher operating energy by connecting like-polarity terminals of adjacent lithium batteries. To combine lithium batteries in parallel strings, connect all like-polarity wires on adjacent lithium batteries to an appropriately sized terminal block for your application.

Refer to Figure 3 for an example of four 12.8V lithium batteries connected in parallel.

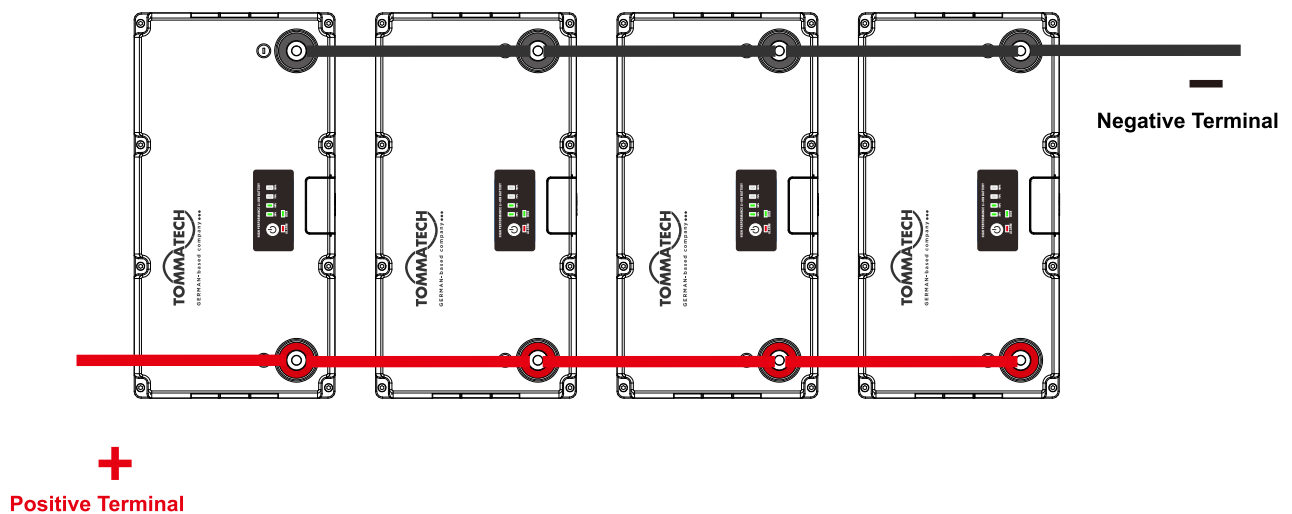

Figure 3 Example of a 4P1S Configuration



CAUTION

- Do not connect different batches, different types, old and new batteries in parallel.
- Ensure the battery voltage difference is below 100mV before parallel connection to avoid high pulse current.
- Ensure every battery have 3A charge/discharge current.
- The parallel application can only extend the working time, and cannot increase the charging or discharging current.

Charging Batteries

The 12.8V Lithium battery is compatible with common 12V Lead-acid battery chargers. Chargers that require the detection of voltage at the battery terminals to charge may fail to wake the lithium battery from a state of under-voltage protection. Constant Voltage (CV) chargers may result in an inrush of current due to the low impedance of the cells, interrupting the charge. Reset the charger and continue charging normally if the charger trips. The constant current (CC) chargers is recommended strongly.

To charge a single 12.8V lithium battery, the maximum charge voltage is 14.6V and the maximum charge current is refer to Table 1. Any inrush current may cause over current or short circuit protection.

Once you reach end-of-charge voltage, apply a constant voltage hold at this voltage until the current decays to almost zero. This charges the cells to 100% state of charge (SOC). Refer to below figure for an illustration.

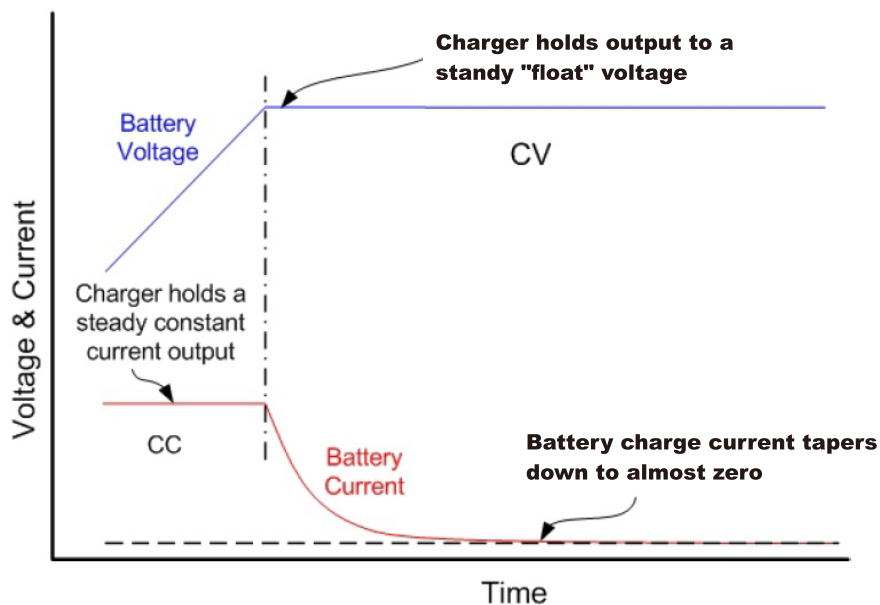

Battery Voltage and Current During Charge

Note:

For 12.8V Lithium battery, the minimum charging voltage is 13.7V, otherwise the battery will not be fully charged.

ON/OFF Button and LED Indicators for BTR-MRN3-12.8V-200AH and BTR-MRN3-25.6V-100AH

For new generation lithium battery, if there are no charge or discharge for 24 hours, the lithium battery will enter into sleep mode to save energy and it can still be measured a OCV (>10V), any charge or discharge operation will active the lithium battery.

If the lithium battery was over-dicharged protection, the BMS will enter into sleep mode after 5 min. there are no OCV at this status. only charge operation can active the lithium battery.

For MRN3 series, it can be also support to press ON/OFF button 6 seconds to active or switch off a lithium battery.

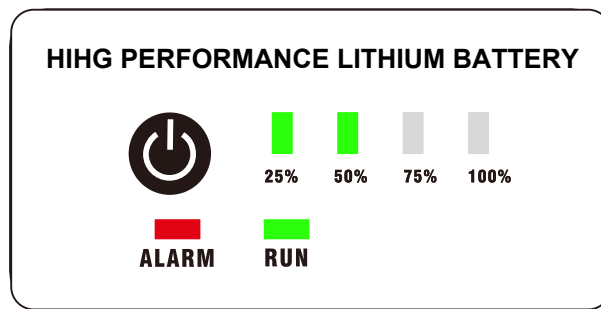

ON/OFF button and LED indicators for MRN3

Status	Normal Warning Protection	RUN	ALM	SOC				Description
		●	●	●	●	●	●	
Shut down	Dormancy	OFF	OFF	OFF	OFF	OFF	OFF	
Standby	Normal	Flash 1	OFF	Follow module capacity				Standby
	Warning	Flash 1	Flash 2	Follow module capacity				Module at low voltage
Charge	Normal	ON	OFF	Follow module capacity				
	Warning	ON	Flash 2	Follow module capacity				
	Over-charge Protection	ON	OFF	ON	ON	ON	ON	LED turn to standby if no power supply
	Temperature / over-current / BMS fault protection	OFF	OFF	OFF	OFF	OFF	OFF	Stop charging
Discharge	Normal	ON	OFF	Follow module capacity				
	Warning	ON	Flash 2	Follow module capacity				
	Under voltage Protection	OFF	OFF	OFF	OFF	OFF	OFF	Stop discharging
	Temperature / over-current / short circuit / BMS fault protection	OFF	ON	OFF	OFF	OFF	OFF	Stop discharging
Failure		OFF	ON	OFF	OFF	OFF	OFF	Stop charging and discharging

Note:
Flash 1: light 0.25s/o ff3.75s; Flash 2: light 0.5s / o ff1.5s

Communication Port for MRN3

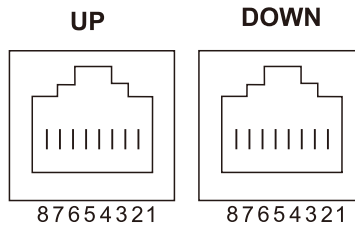

UP	
PIN	Description
1	LED -
2	O/F/LED+
3	O/F
4	CAN H
5	CAN L
6	COMG
7	RS485-A
8	RS485-B

DOWN	
PIN	Description
1	/
2	SWB
3	SWA
4	CAN H
5	CAN L
6	COMG
7	RS485-A
8	RS485-B

Note :

1. For parallel connection, it supports to do communication between batteries.

Communication connection

The lithium battery BMS default ADD is 0, if the lithium battery needs to do communication with inverter or there are 2 or more batteries connect in parallel. it needs set ADD. The below accessories is necessary for communication setting and connection.

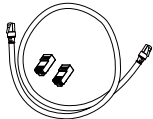

Communication cable- 586B, CAT5e, 1m



CAN terminal resistor for parallel communication (Blue color, PIN4-PIN5 120 Ohm resistor)



Automatic coding parts for parallel batteries ADD automatic coding (Gray color, PIN2-PIN3 short together)

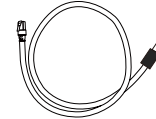

Optional Part
RS485-USB device
Only for install engineer and after-sale engineer.

- Step 1. Connect the power cable between lithium batteries. Make sure the screws are tight.
- Step 2. Connect communication cable lithium batteries and CAN terminal resistor.

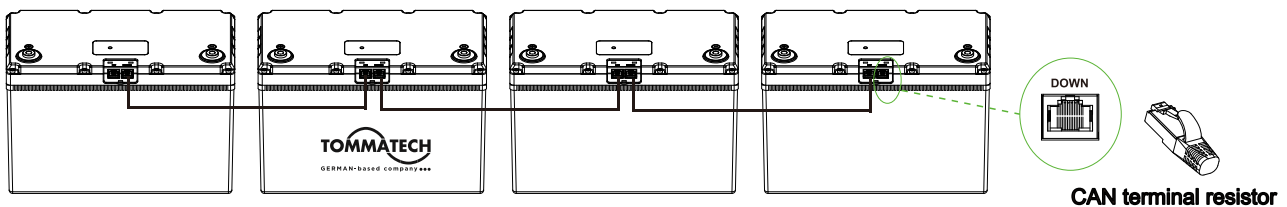

Step 3. Press ON/OFF button 6s to active all batteries. the battery SOC indicator will on.

Step 4. Insert automatic coding parts to BAT-1 UP port. the BAT-1 RUN & ALARM LED will start to flash at the same time which means the BMS start setting ADD automatically. Finally, all LED indicators will become normal which means the BMS ADD coding process is complete.

Setp 5: Remove automatic coding parts and connect RS485-USB cable to PC, it can monitor every battery information by BMS PC software. or connect BAT-1 UP port to inverter.

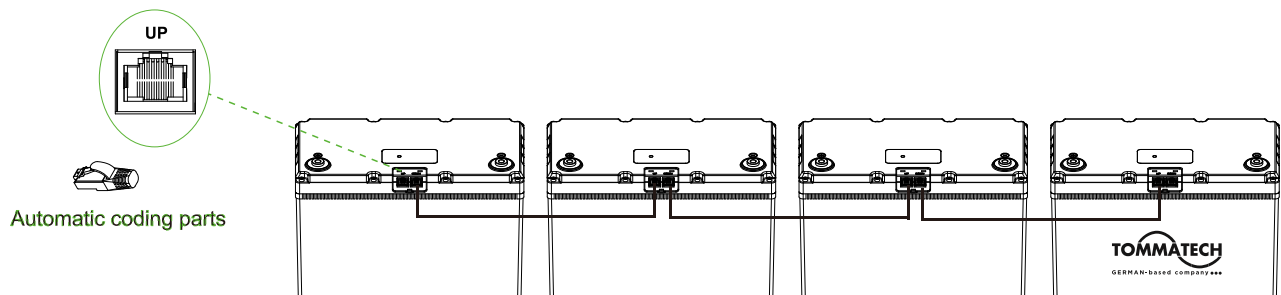

BMS PC software operation

This chapter mainly introduce the BMS PC software operation for MRN3 series.

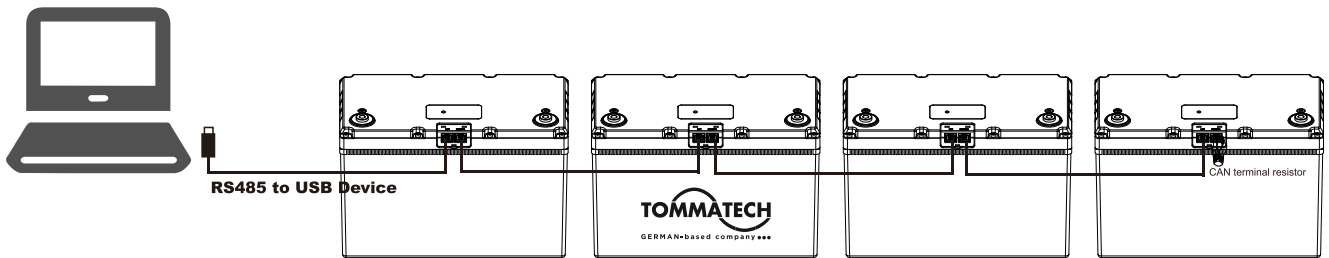

Double click BMSTools.exe to open the software.

Check the battery ADD, USB series Port and band rate-9600, click "connect".

If the communication is normal, the battery realtime information will be listed.

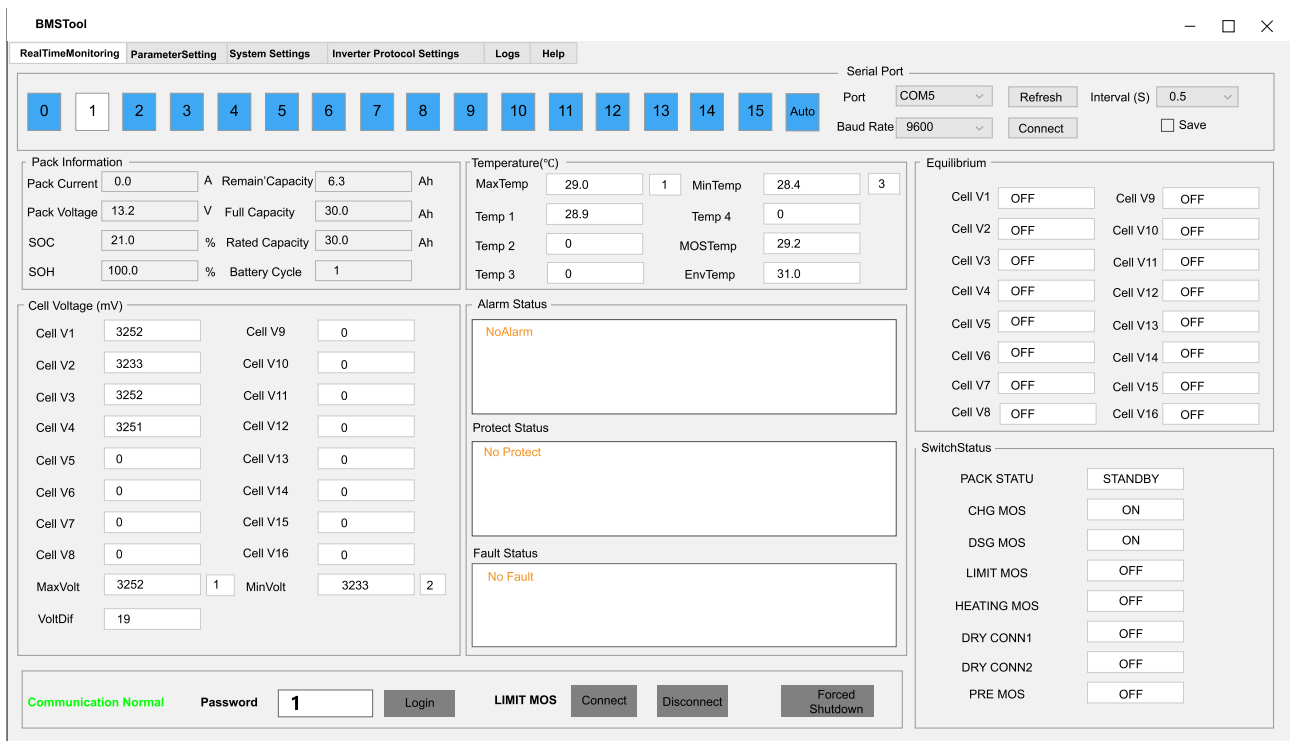

Click" Read", the BMS default parameter will be list. any modify about BMS parameters should be carried out by a professional engineer.

Wrong parameters setting will cause the damage about BMS or lithium battery.

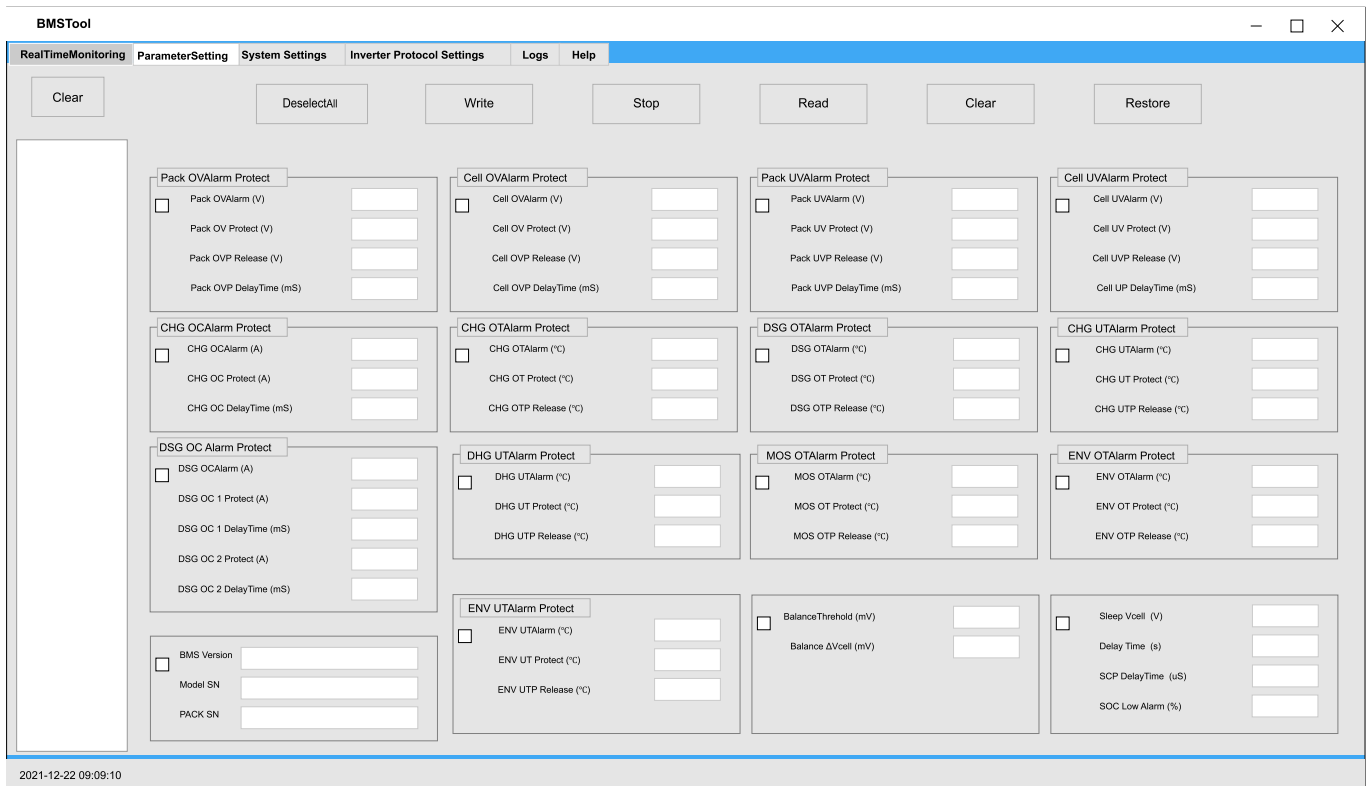

Troubleshooting

The 12.8V / 25.6V Lithium batteries are extremely reliable batteries that provide greater useful life than comparable 12V lead-acid batteries. Despite the high reliability of the 12.8V / 25.6V Lithium batteries, you may encounter situations where the lithium battery does not operate as expected. These situations are typically the result of misuse, abuse or a non-optimal operating or storage environment. This part details potential issues you may encounter with the lithium batteries and the appropriate troubleshooting procedures.

Charger Trips using Constant Voltage

Problem : CV charger trips when charging the batteries. This is due to the low impedance of the battery creating a current inrush.

Solution: Reset the charger and try again.

Terminal Voltage Absent or Low

Problem :

Using a multimeter to check terminal voltage shows the terminal voltage is low. Possible causes for this problem are:

The voltage of a cell within the lithium battery dropped below 2 V, causing the microprocessor to enable under-voltage protection.

The battery's SOC dropped below 5% from either an extended idle period or heavy use, enabling under-voltage protection.

The lithium battery overheated, causing the microprocessor to enable over-temperature protection.

Solution:

To resolve situations where terminal voltage is absent or low:

1. Allow the lithium battery to cool and then recheck terminal voltage.
2. Connect the lithium battery to a charger to wake the battery and recover terminal voltage. Depending on the lithium battery's voltage and state of balance it may take up to 48 hours to completely charge and balance the lithium battery.

Lithium Battery Current Disappears When Charging

Problem:

Lithium battery current disappears when charging. Possible causes for this problem are: The lithium battery overheated, enabling over-temperature protection. The battery pack is out-of-balance. Charger voltage is too high.

Solution:

To resolve situations where current disappears when charging:

1. Allow the lithium battery to cool.
2. Apply a 14.0 V charge voltage for 48 hours to balance the lithium battery pack's cells.
3. Reduce charger voltage to 14.4 V or less.